



# **URAL spareparts catalog**

**CARB**

edition 2020

**Fig. 1**

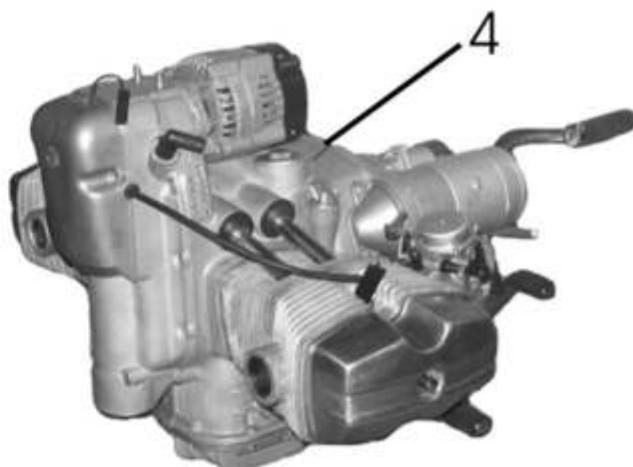
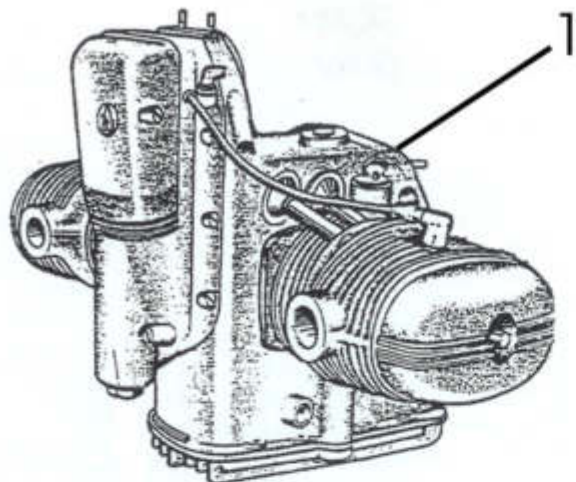
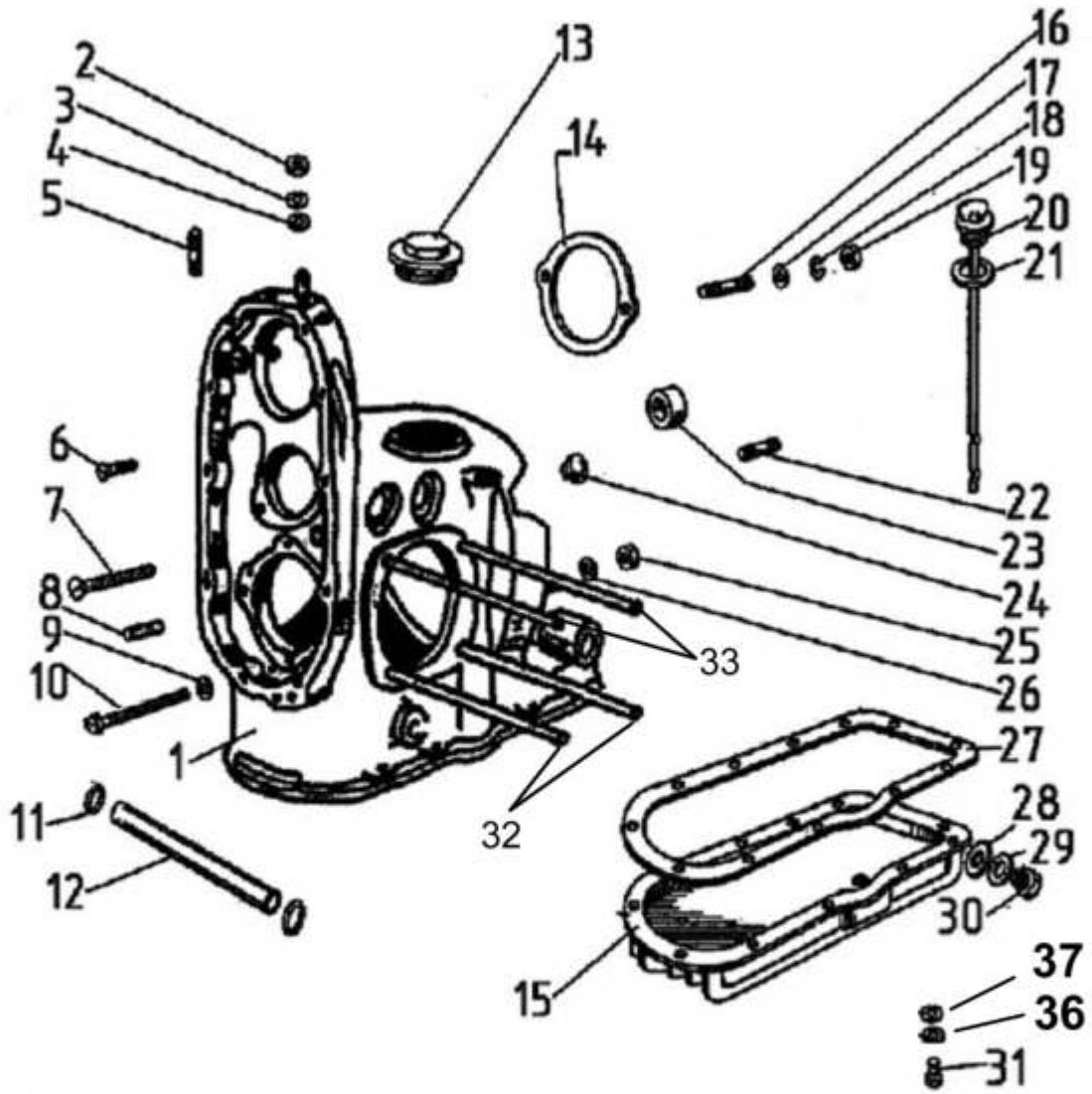


Fig. 2



34



35

Fig. 3

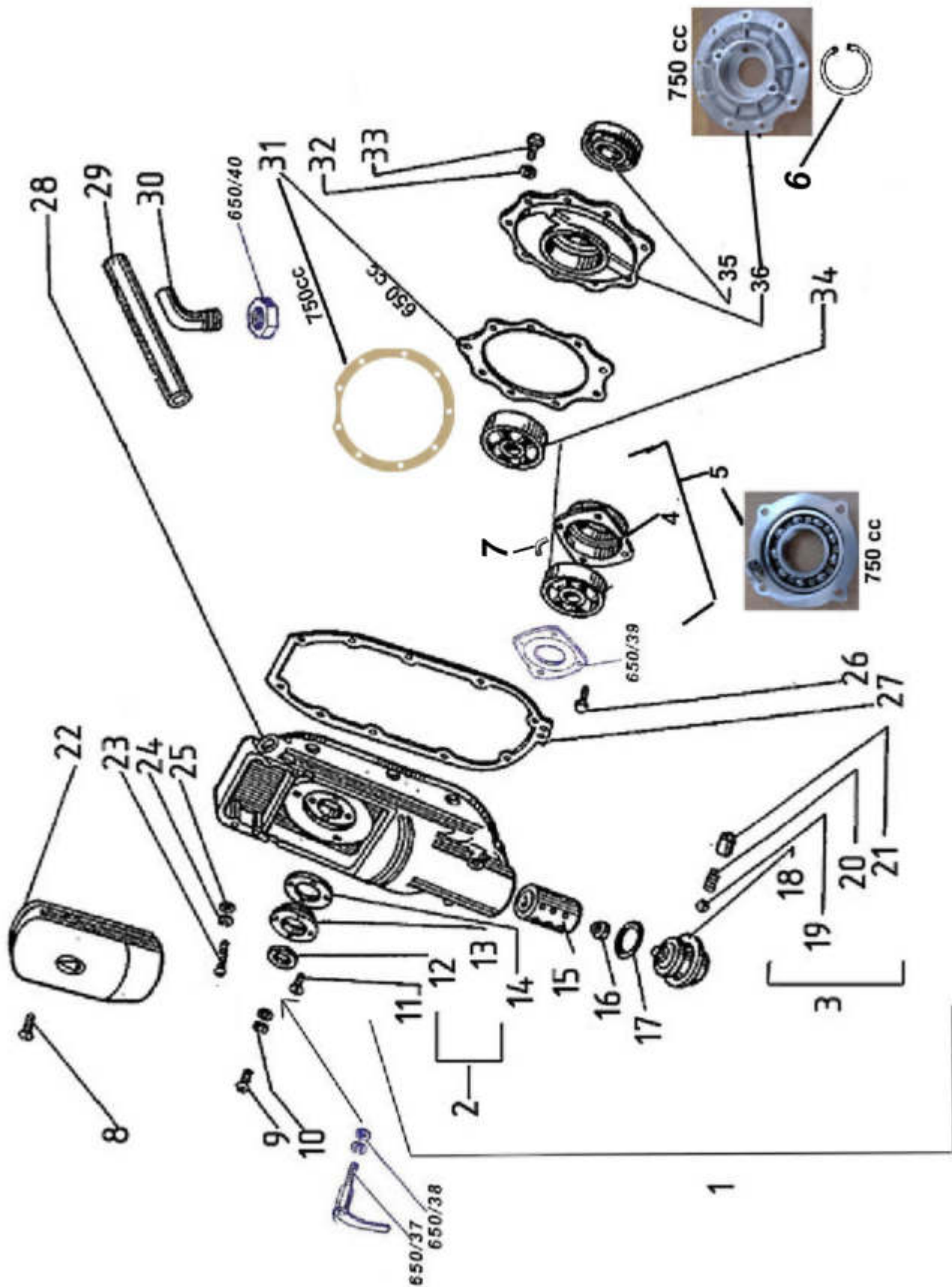
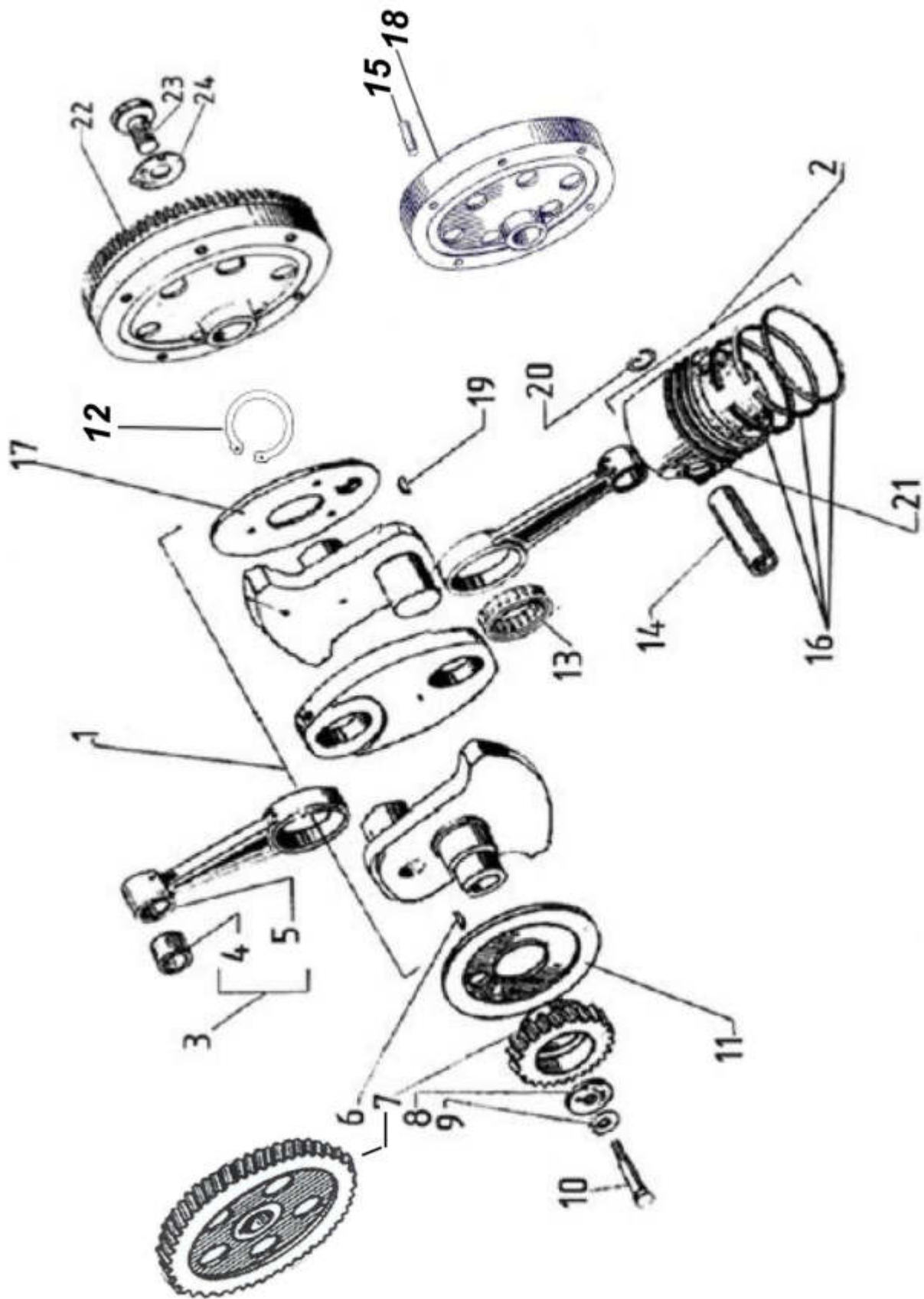


Fig. 4



**Fig. 5**

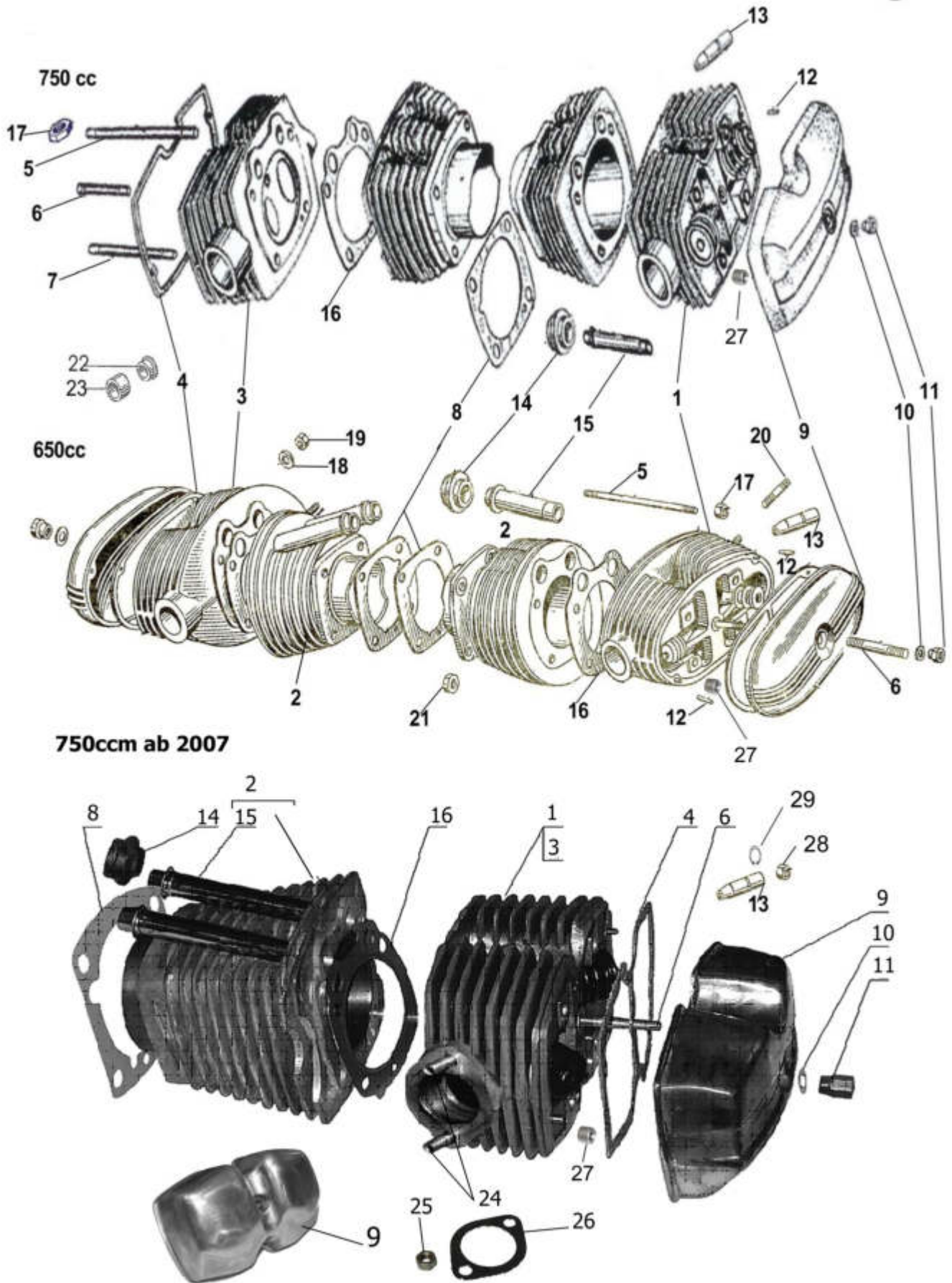


Fig. 6

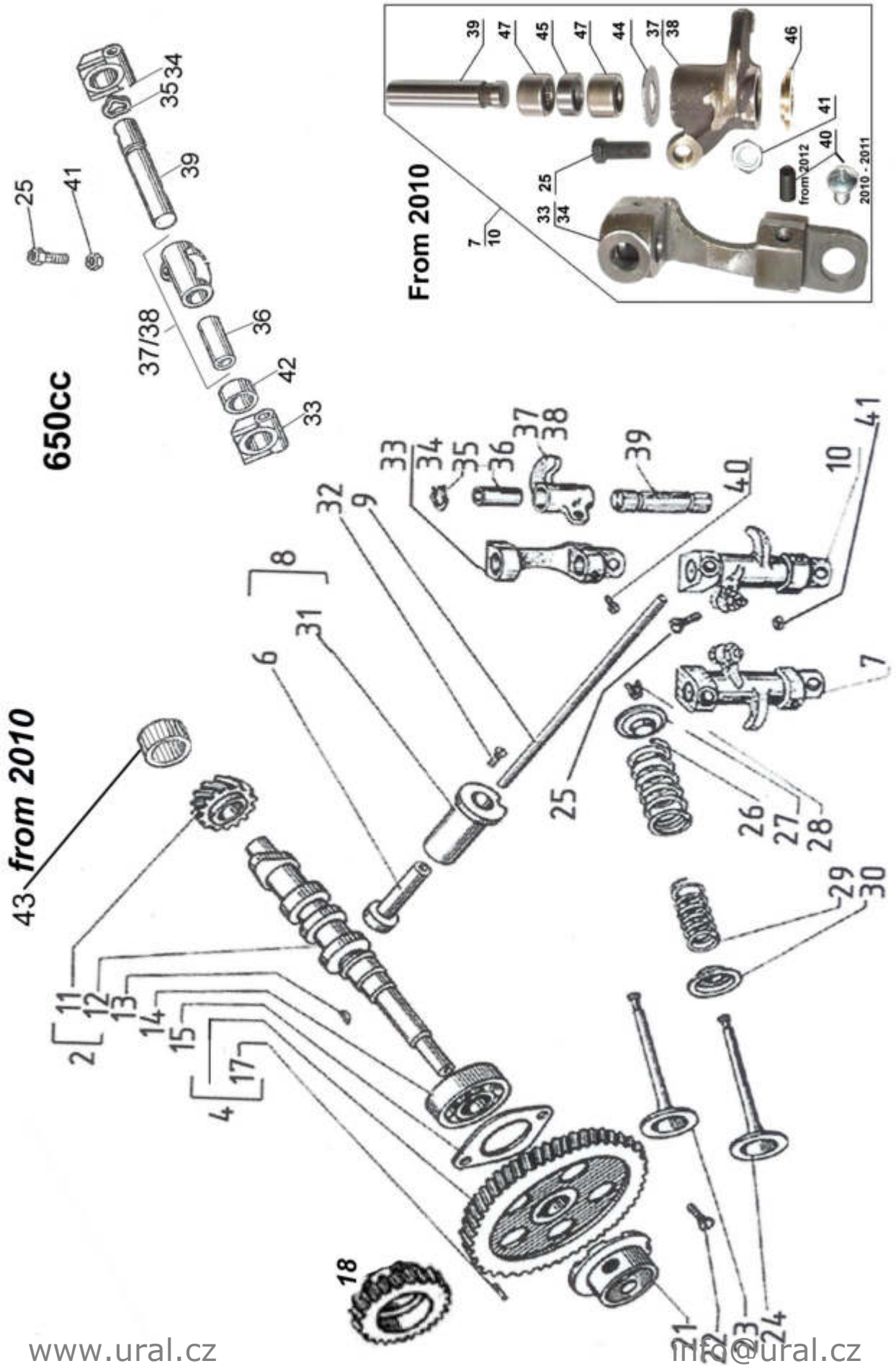
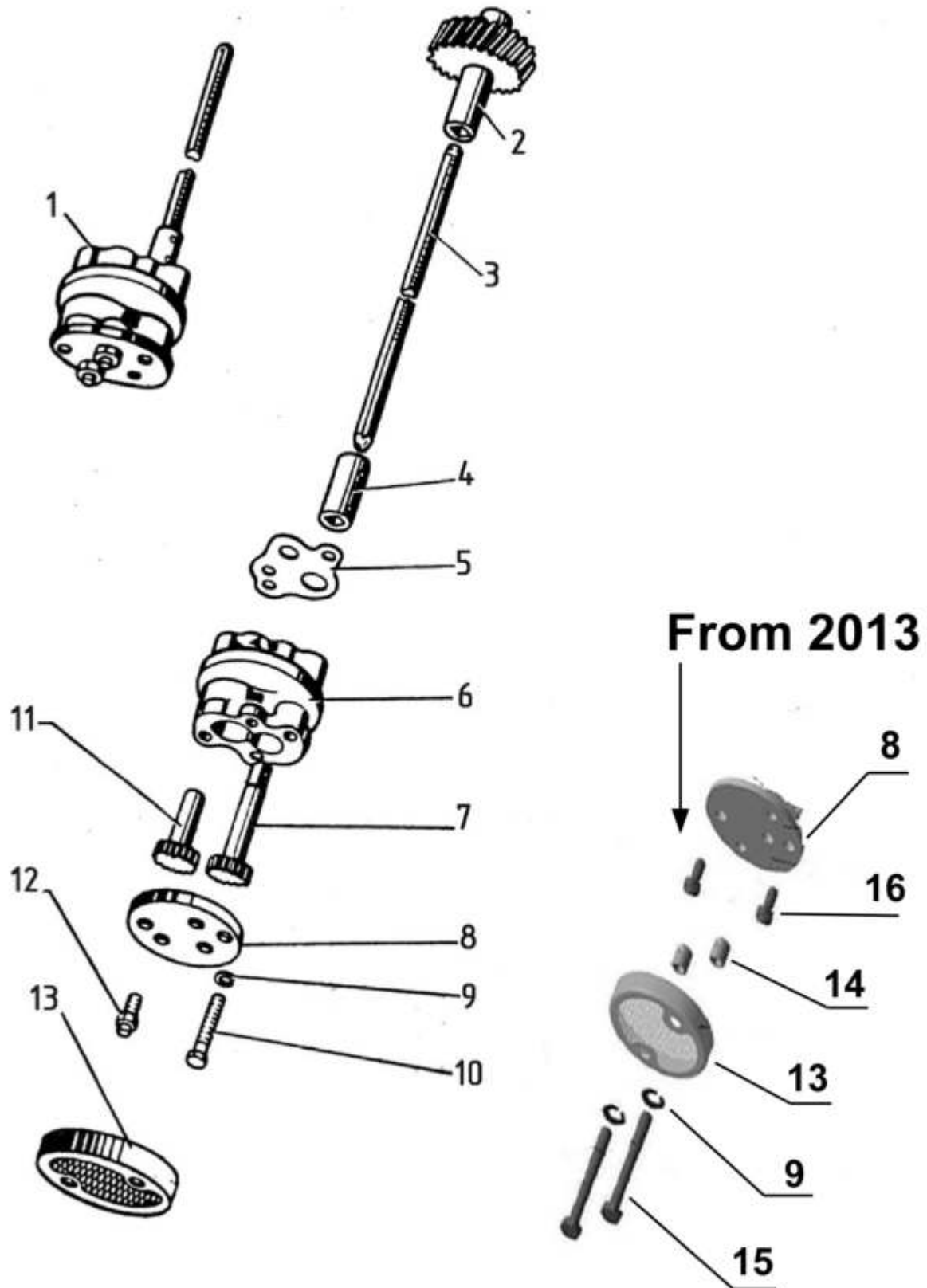
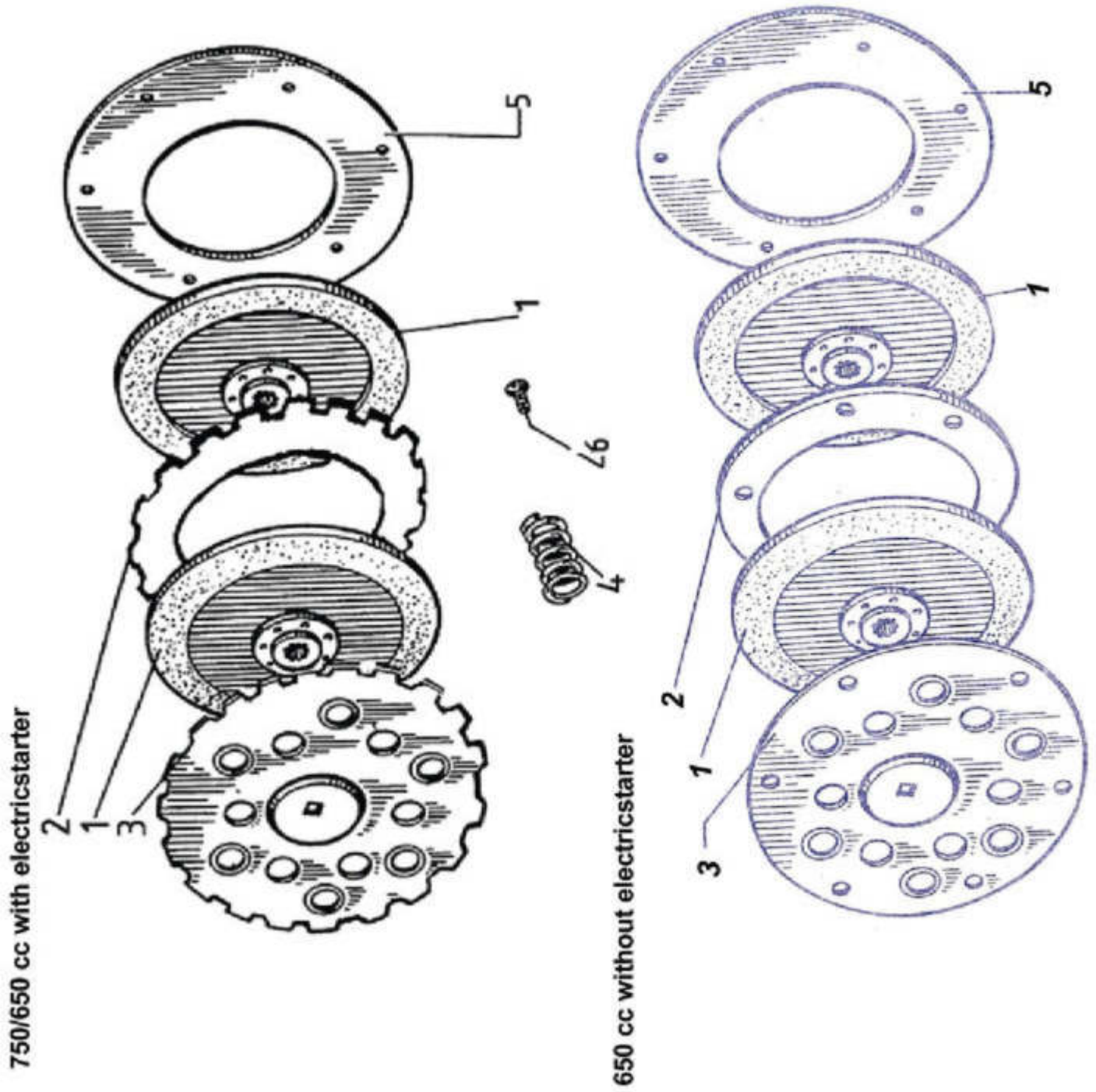


Fig. 7





**Fig. 8**



**Fig. 9**

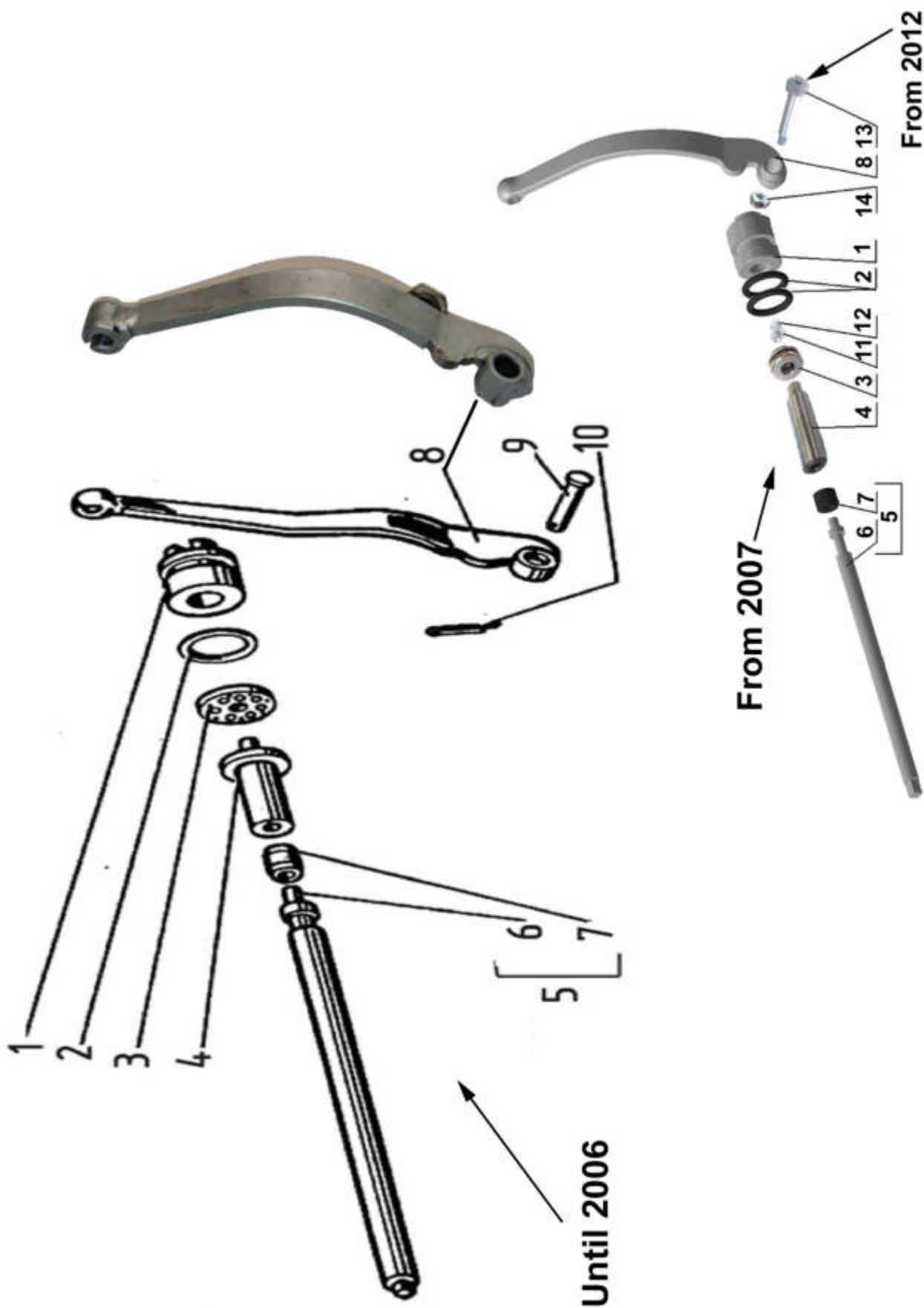


Fig. 10.01

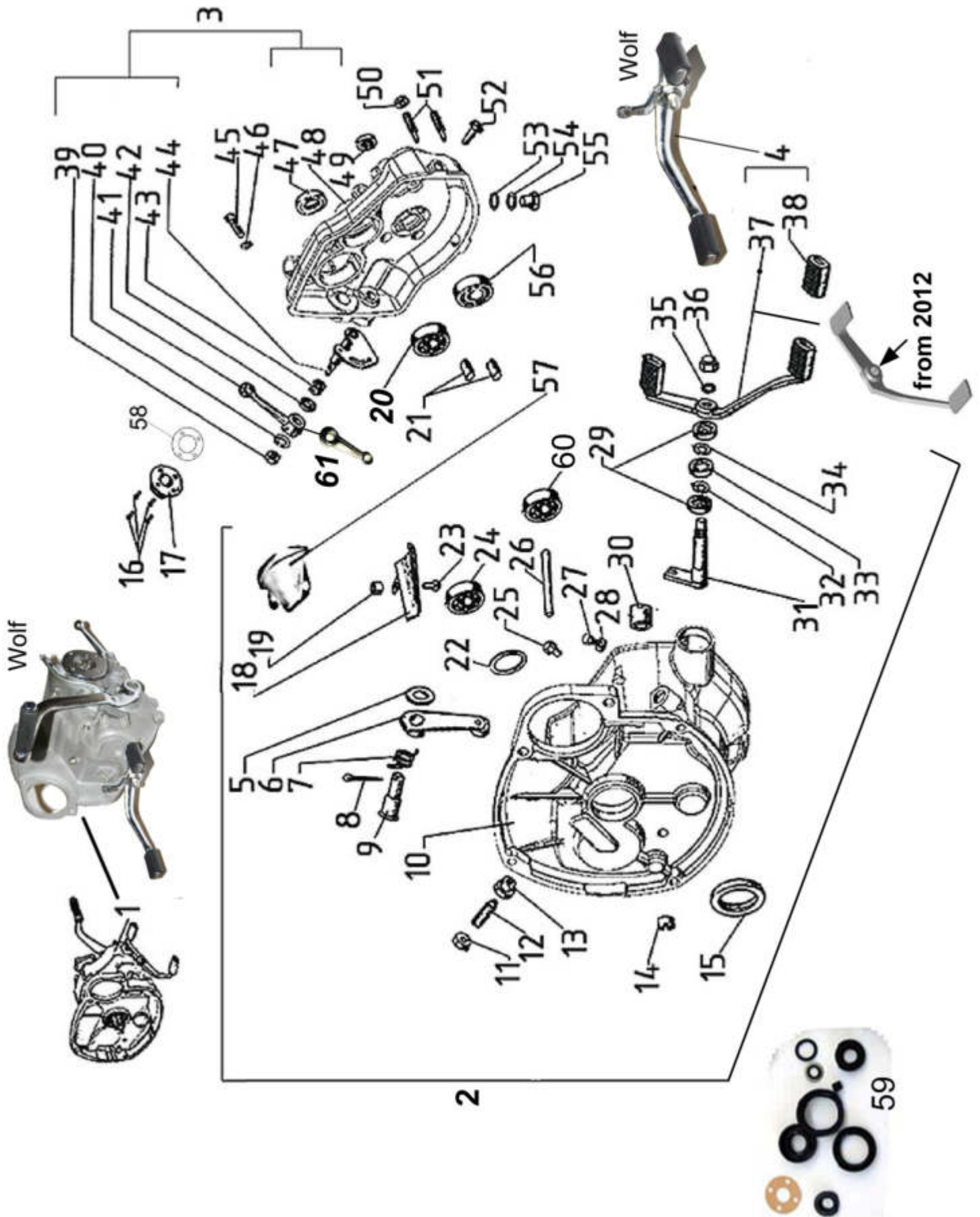
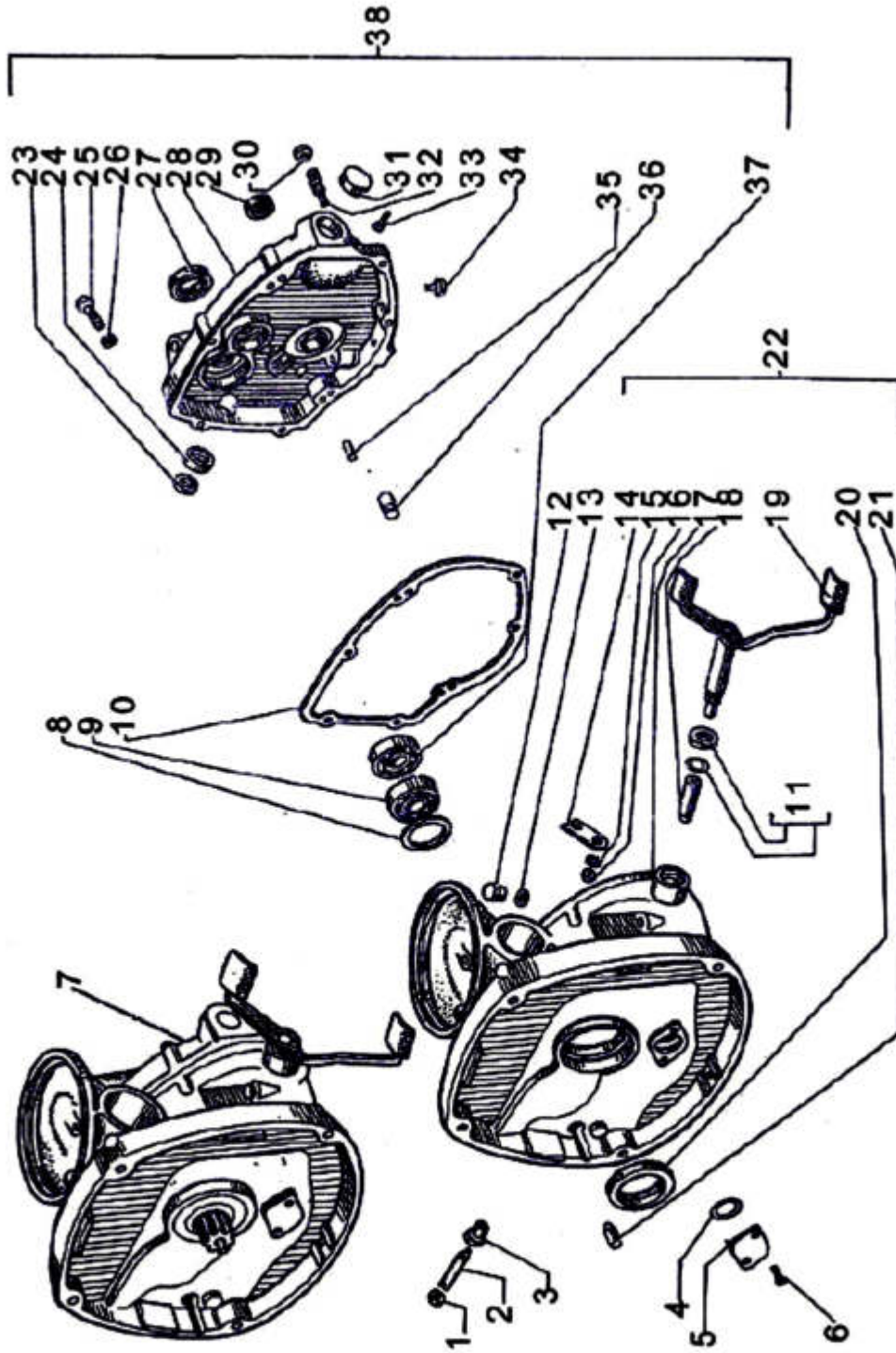
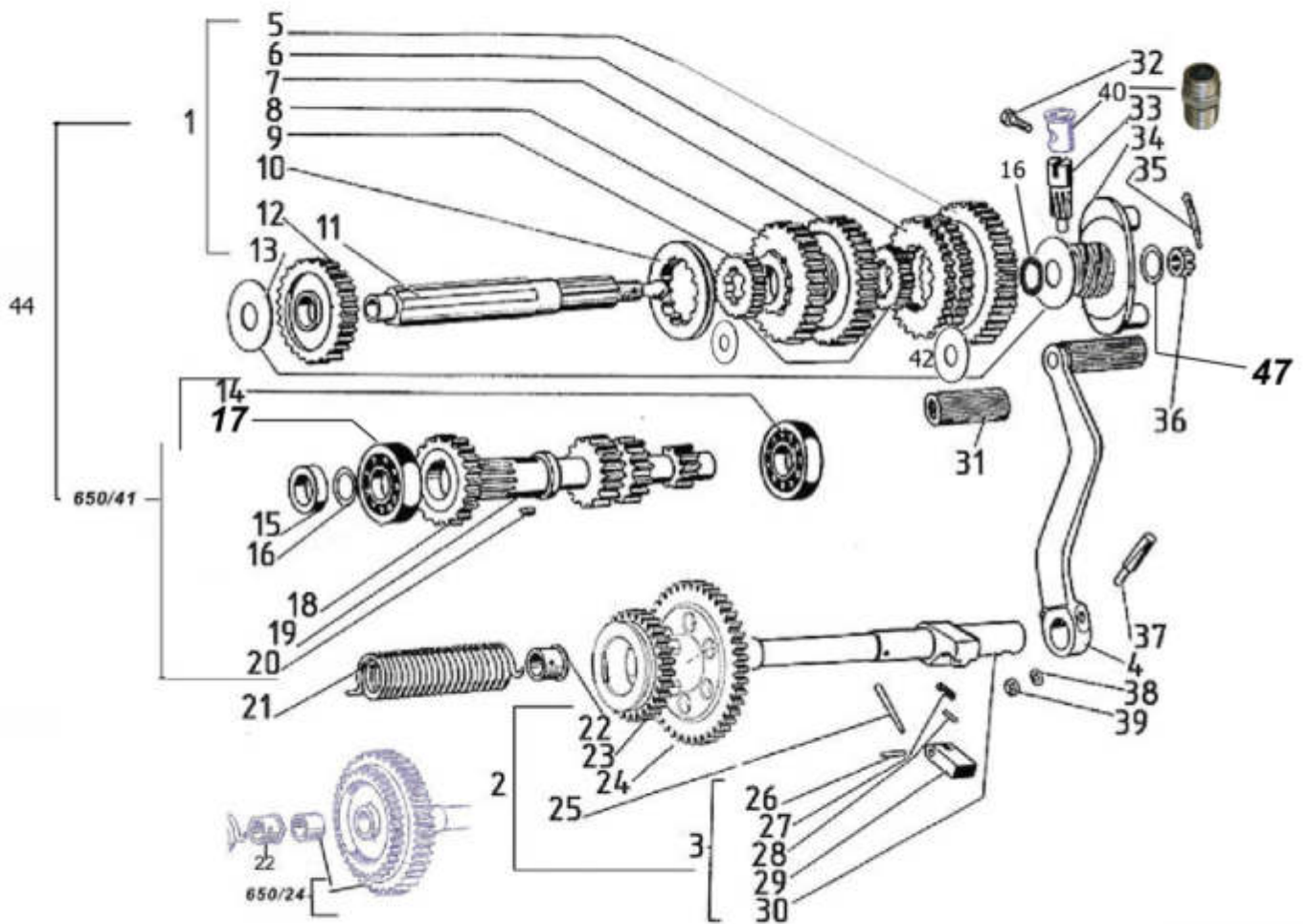


Fig. 10.02



39

**Fig. 11**



**750ccm from 2007**

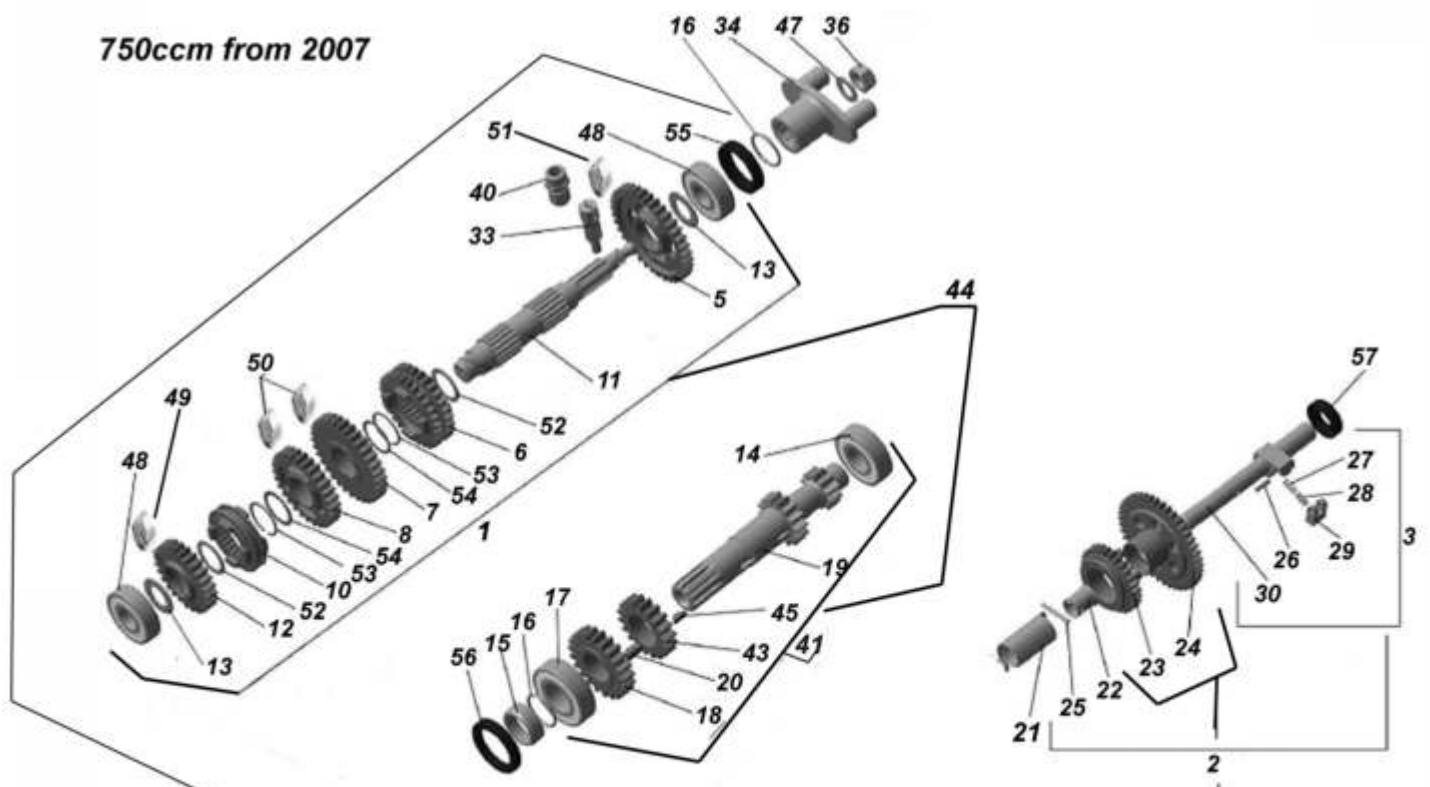
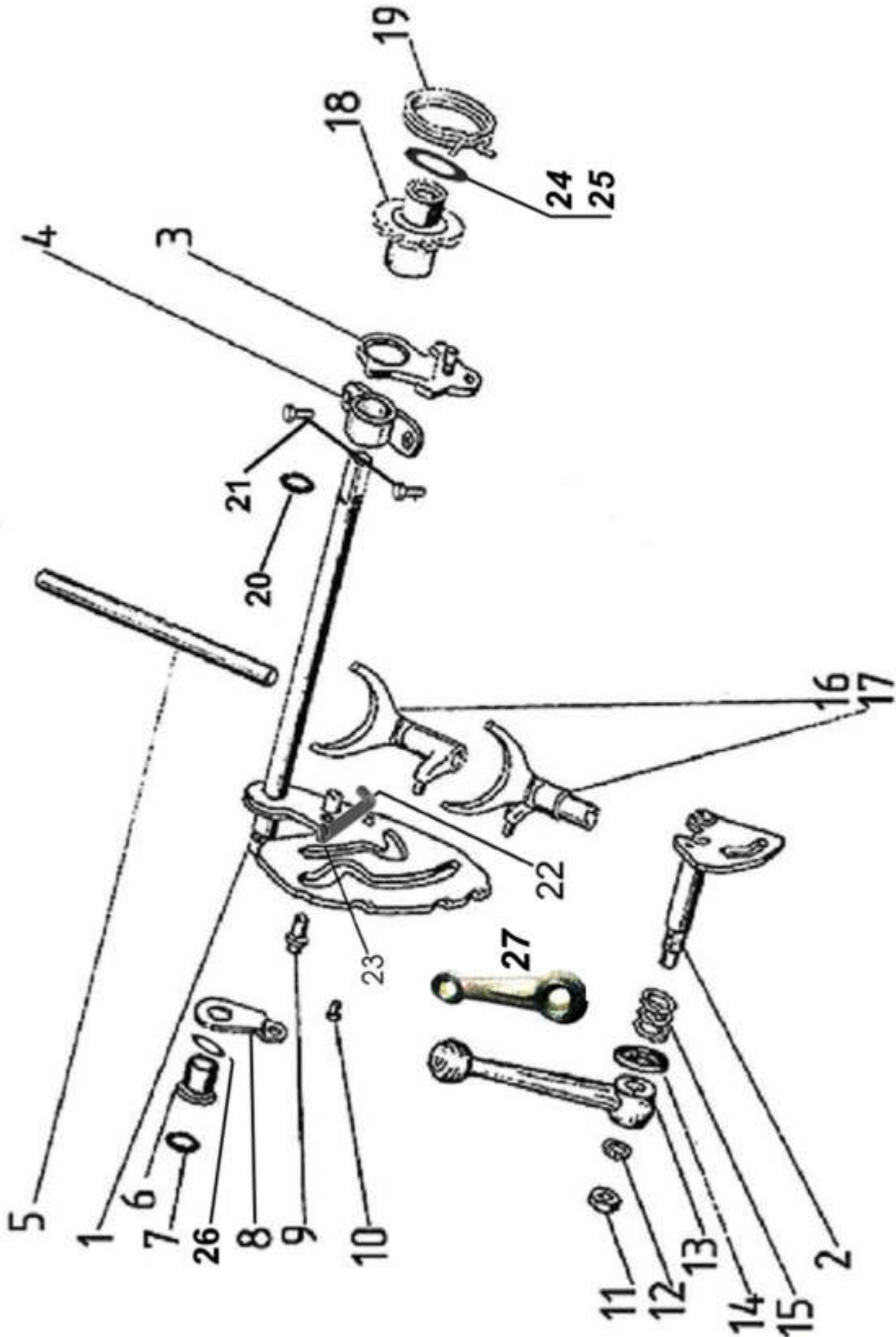


Fig. 12



**Fig. 13**

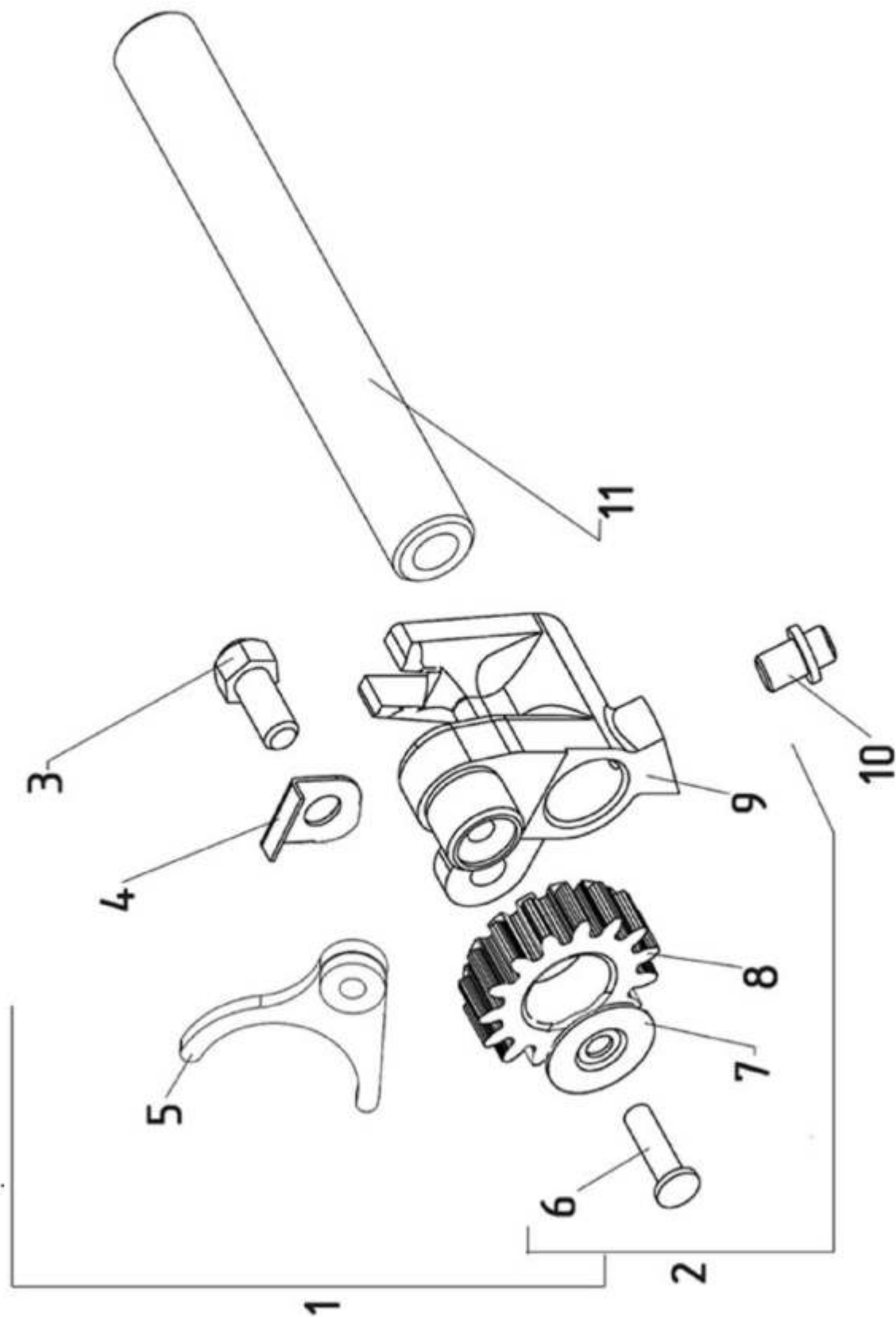


Fig. 14

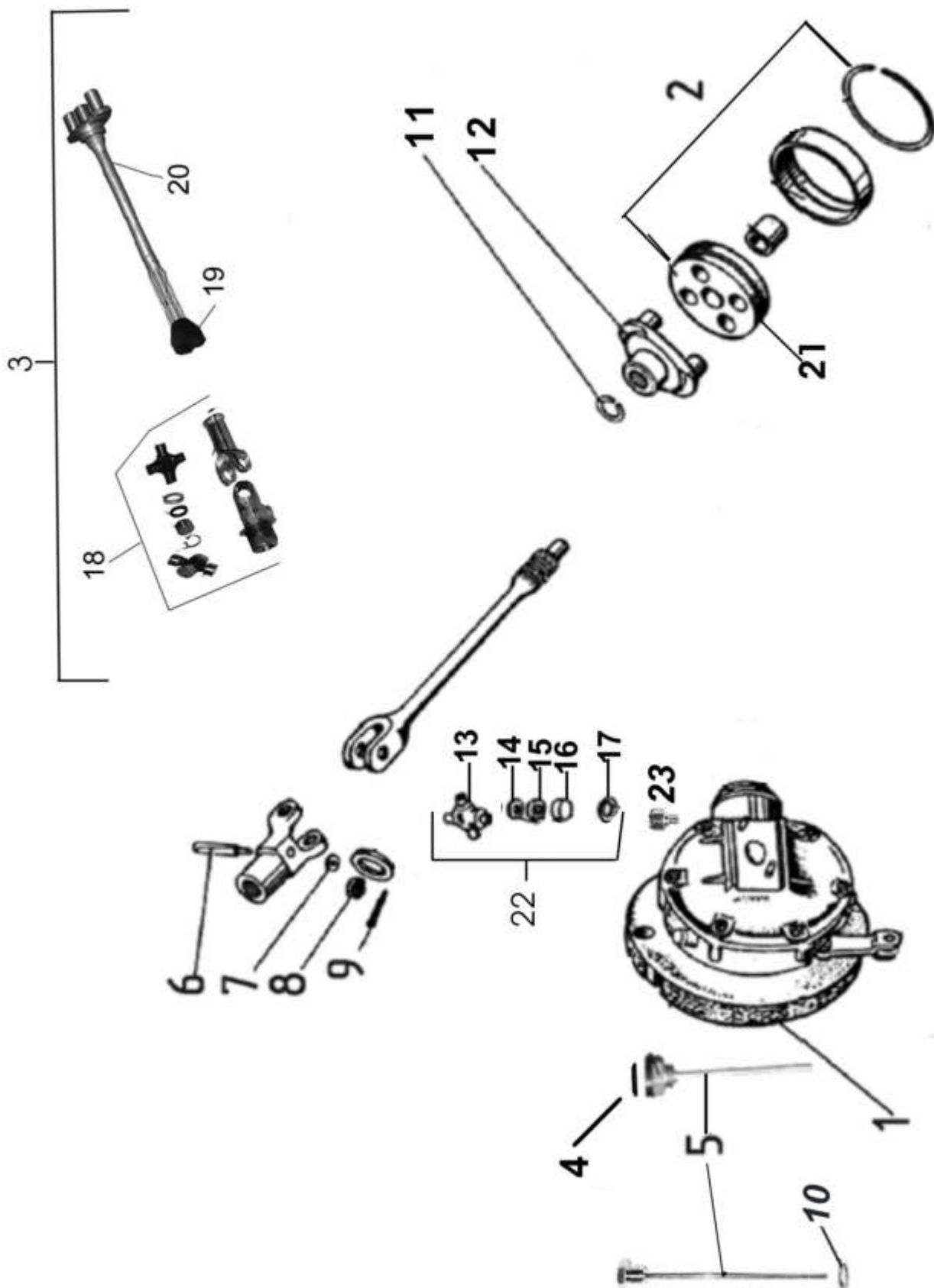
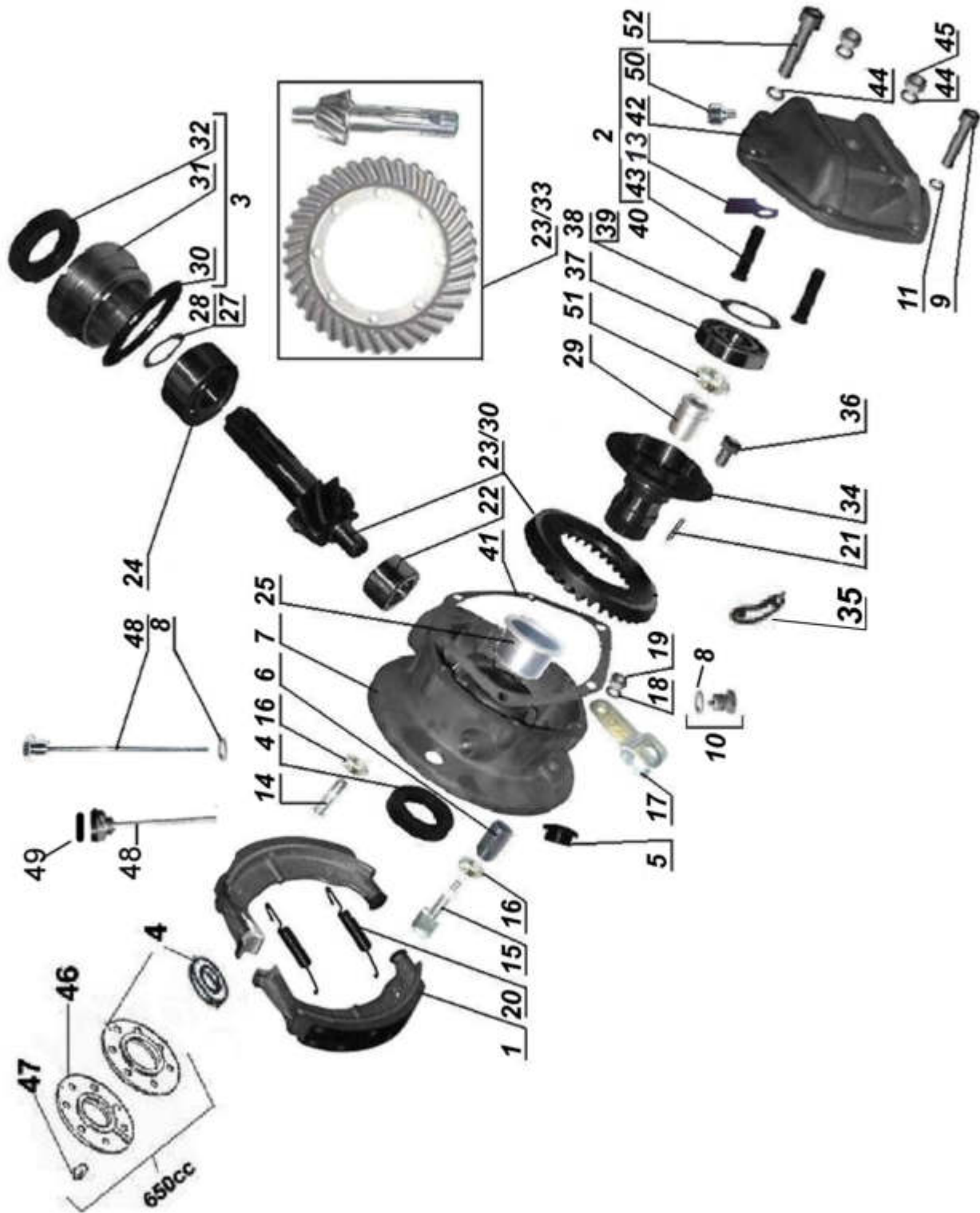




Fig. 15



**Fig. 16**

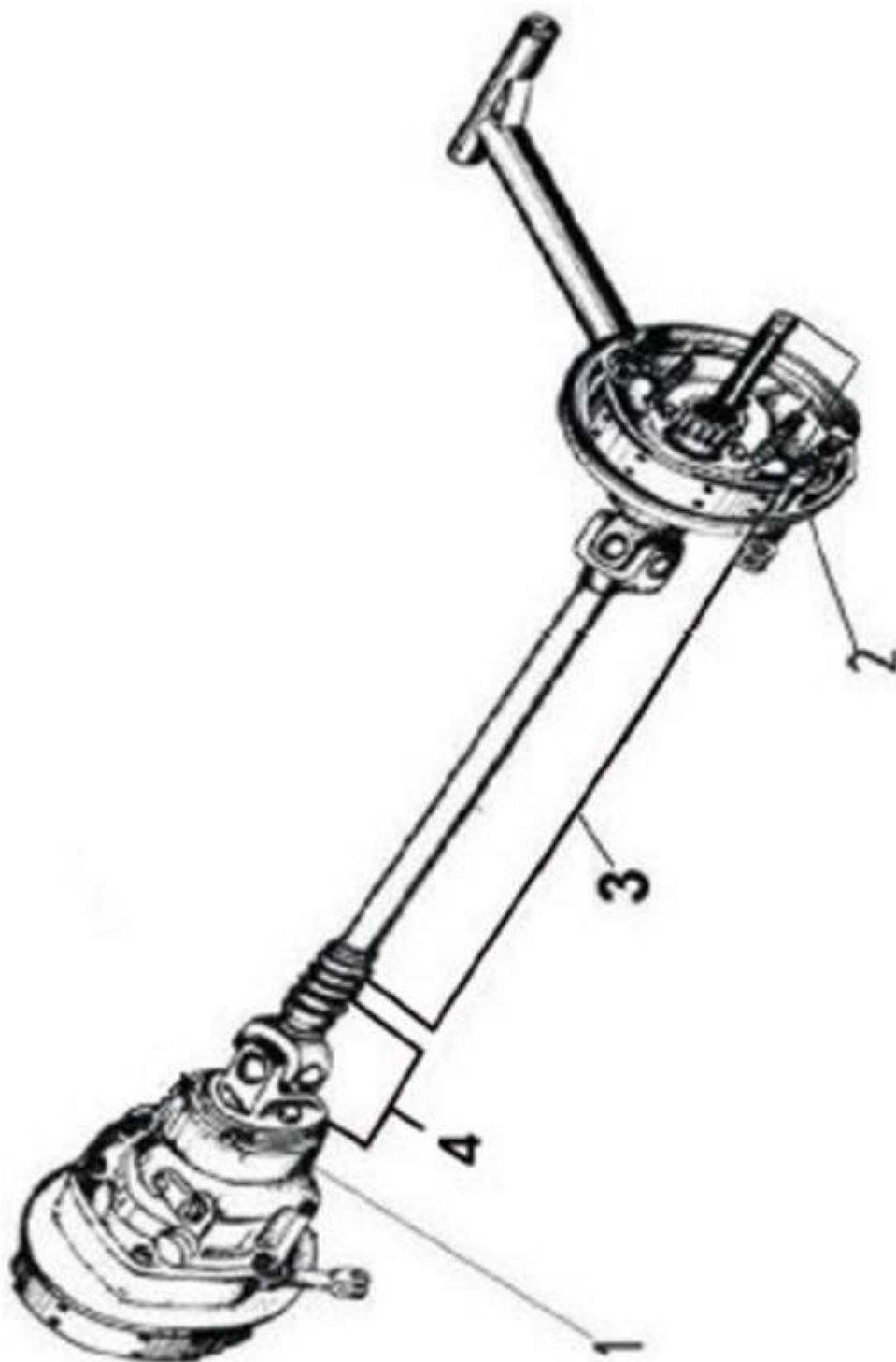


Fig. 17

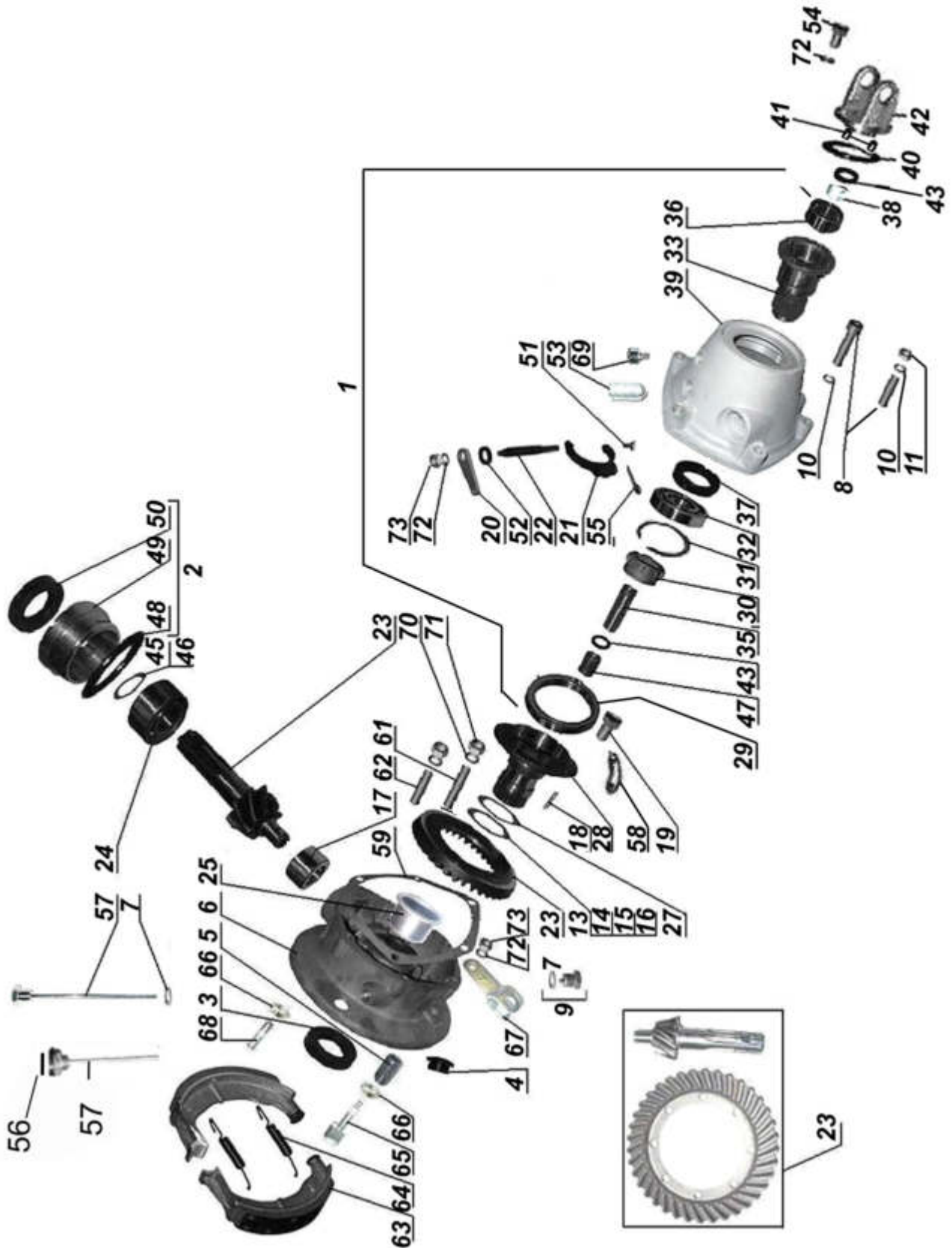


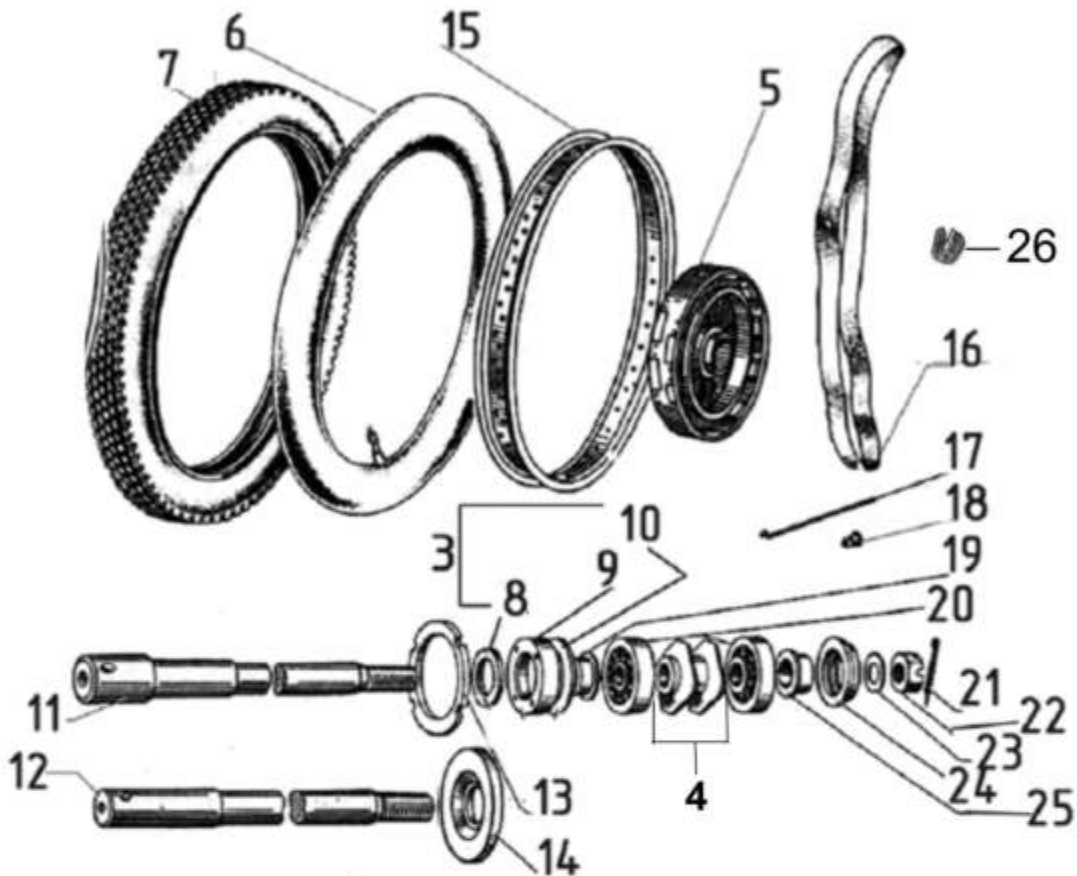
Fig. 18



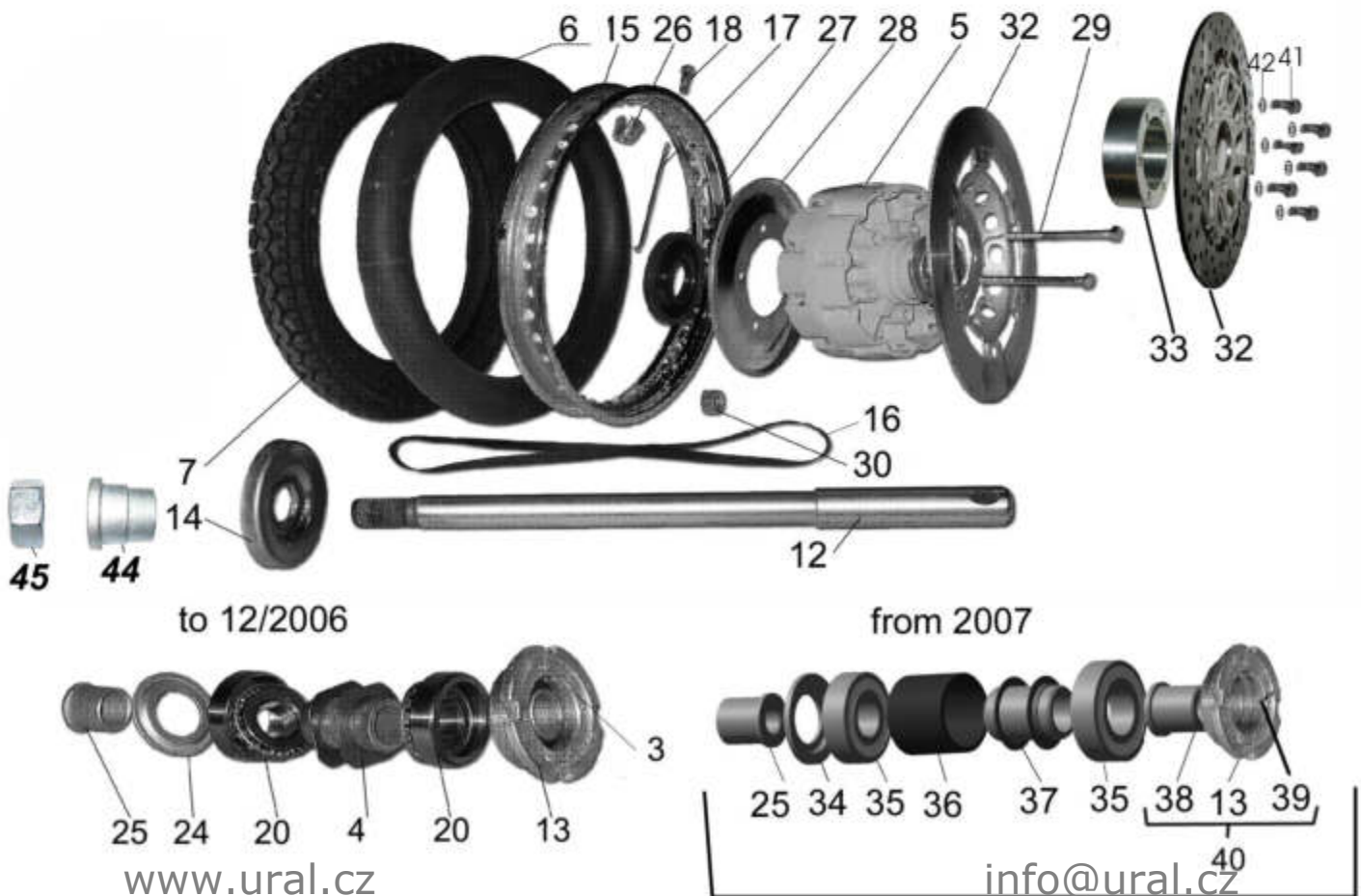
Fig. 19.01



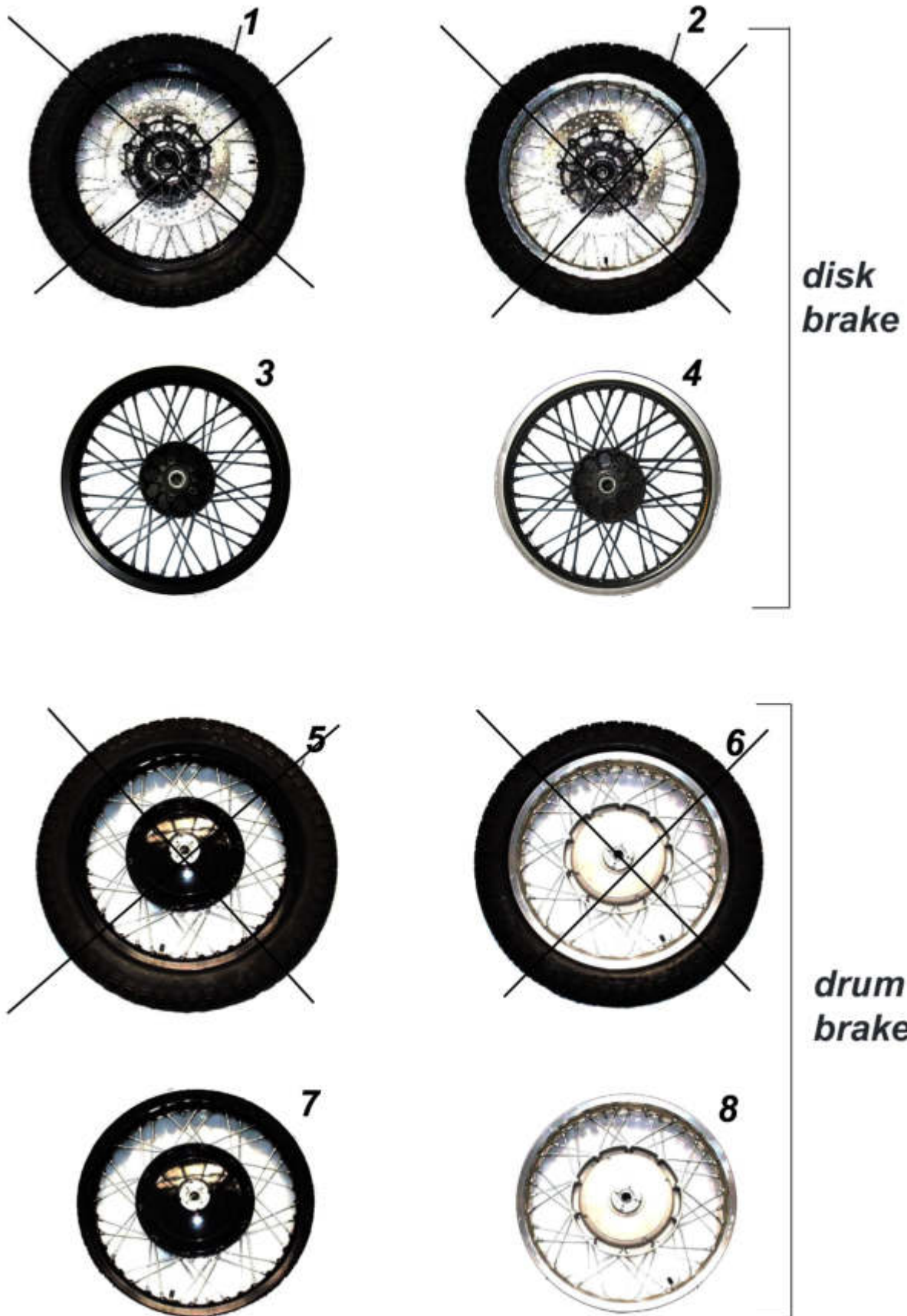
Drum brake



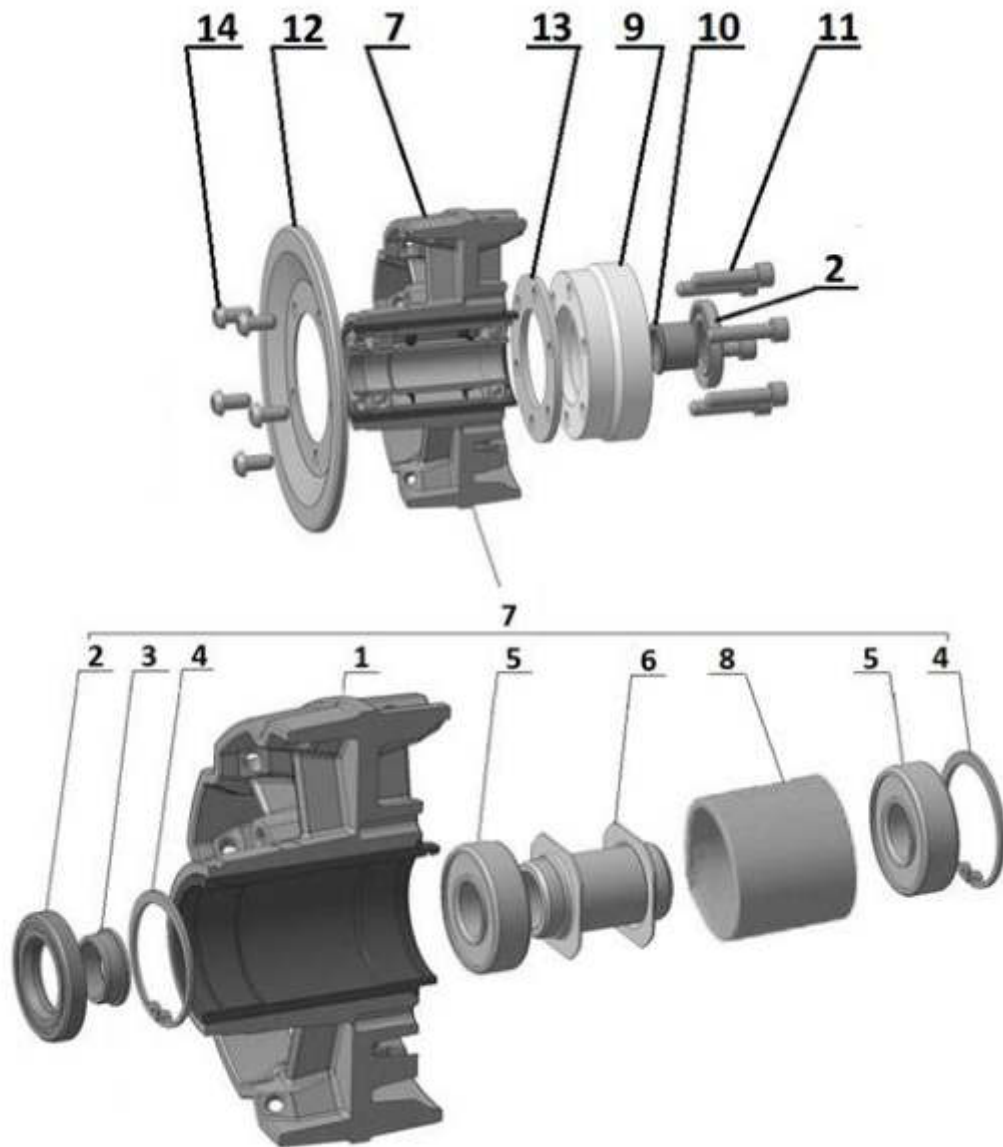
Disk brake



**Fig. 19.02**



**Fig. 19.03**



**Fig. 19.04**

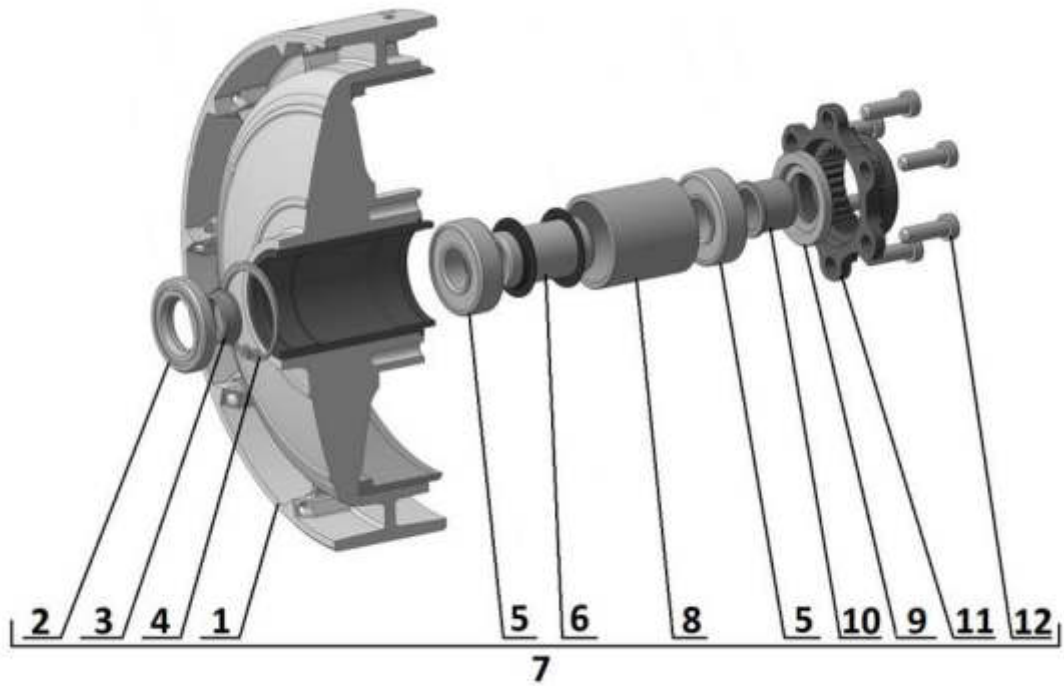
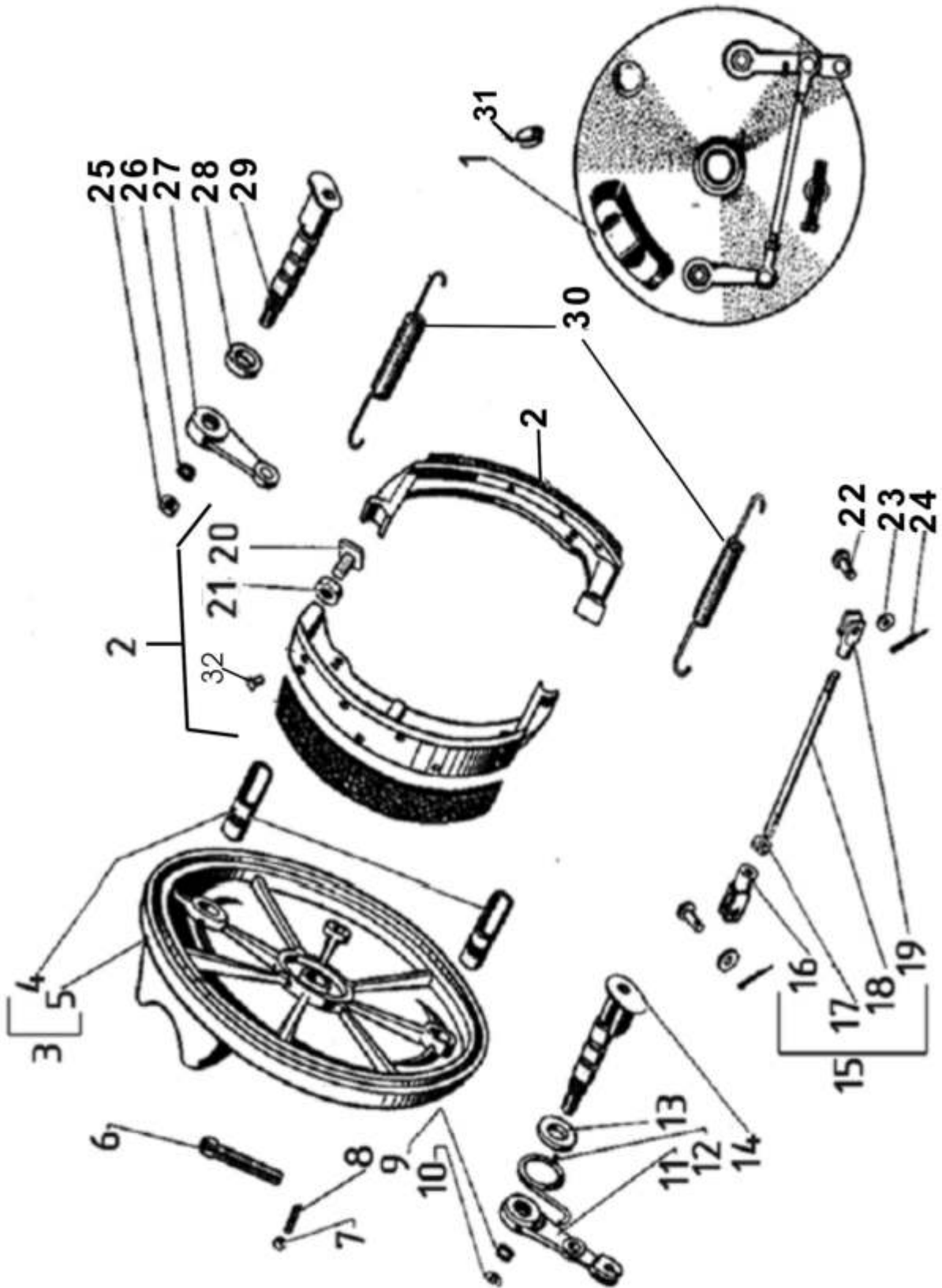


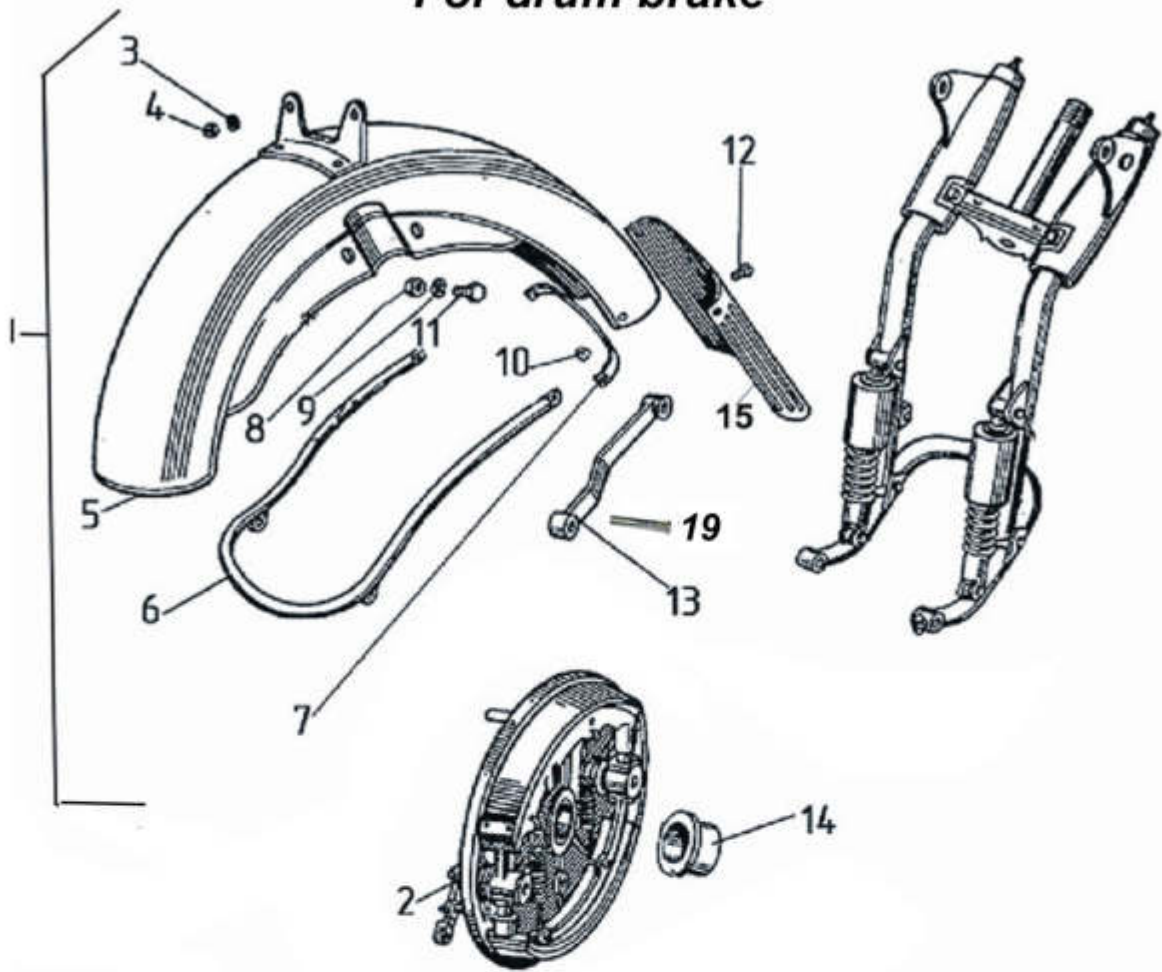


Fig. 20

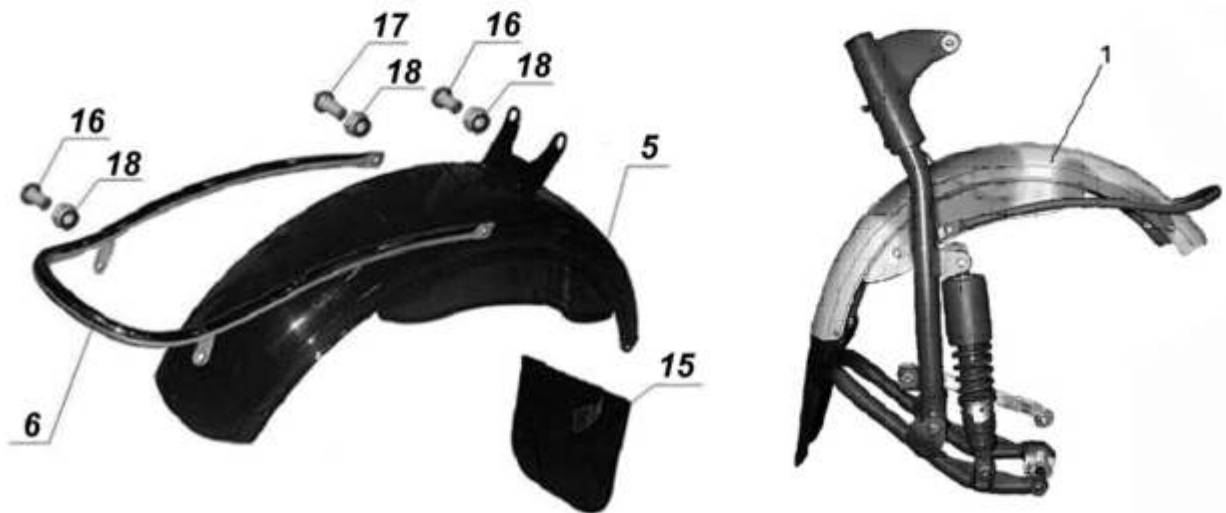




**For drum brake**



**For disc brake**

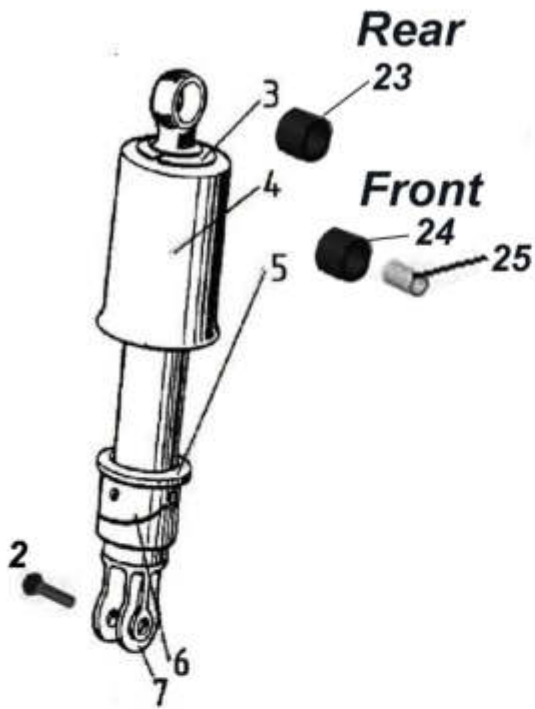


# Fig. 23

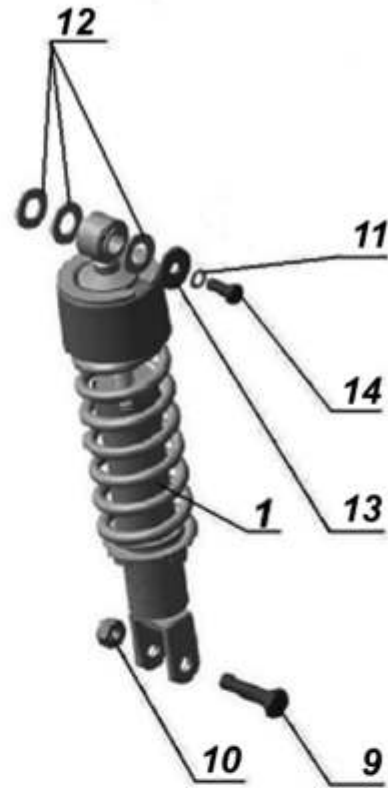


until 2006

Sidecar and rear from 2007



Front from 2007



Retro rear from 2008

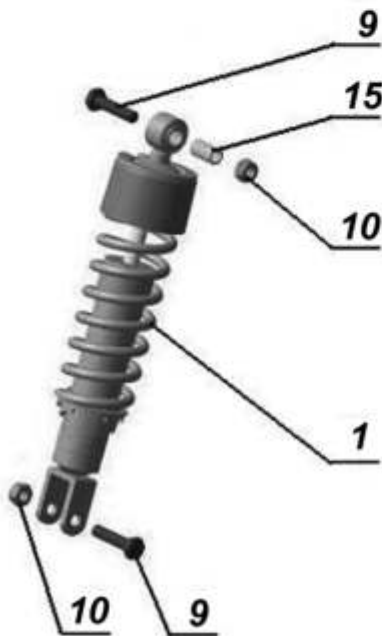
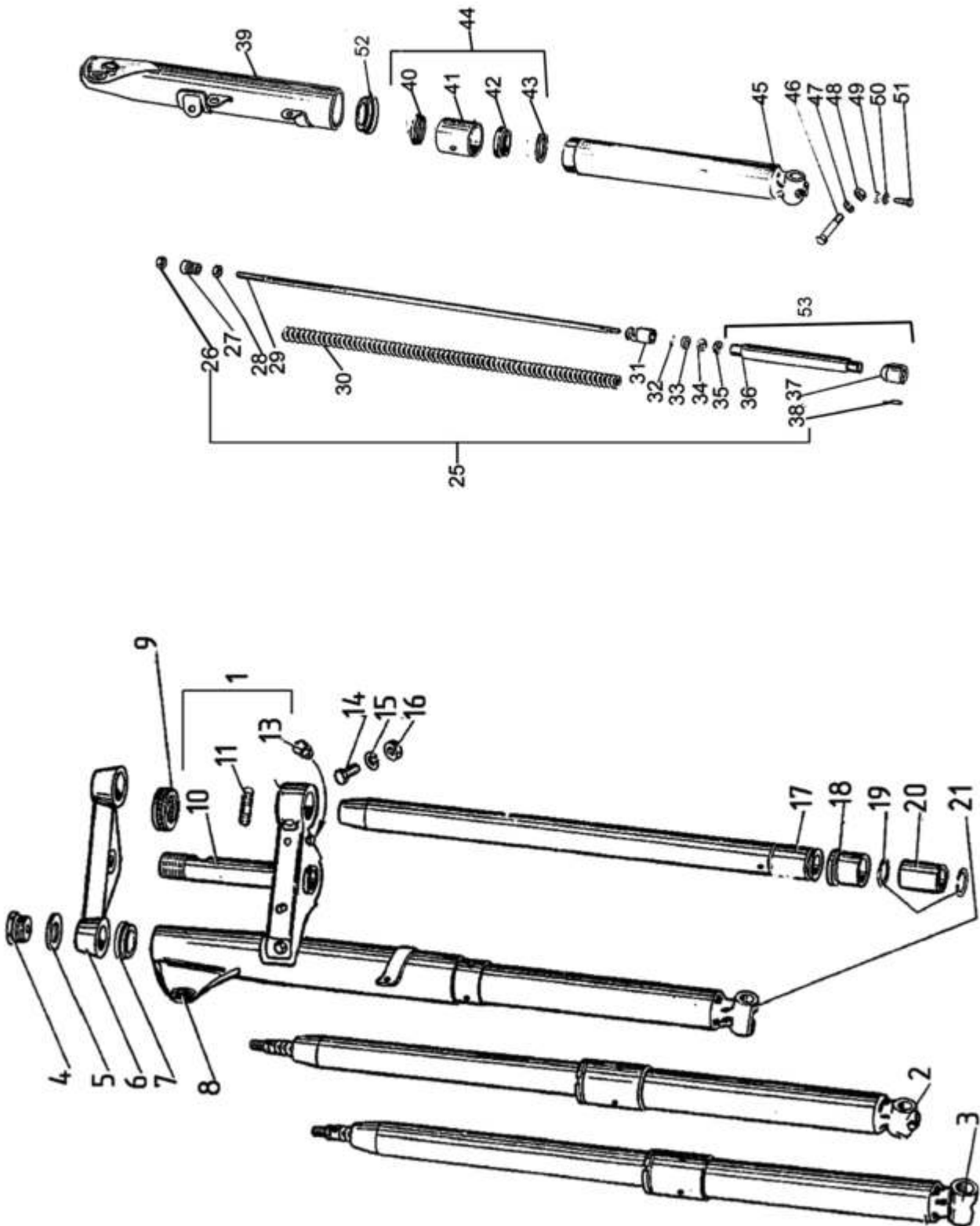


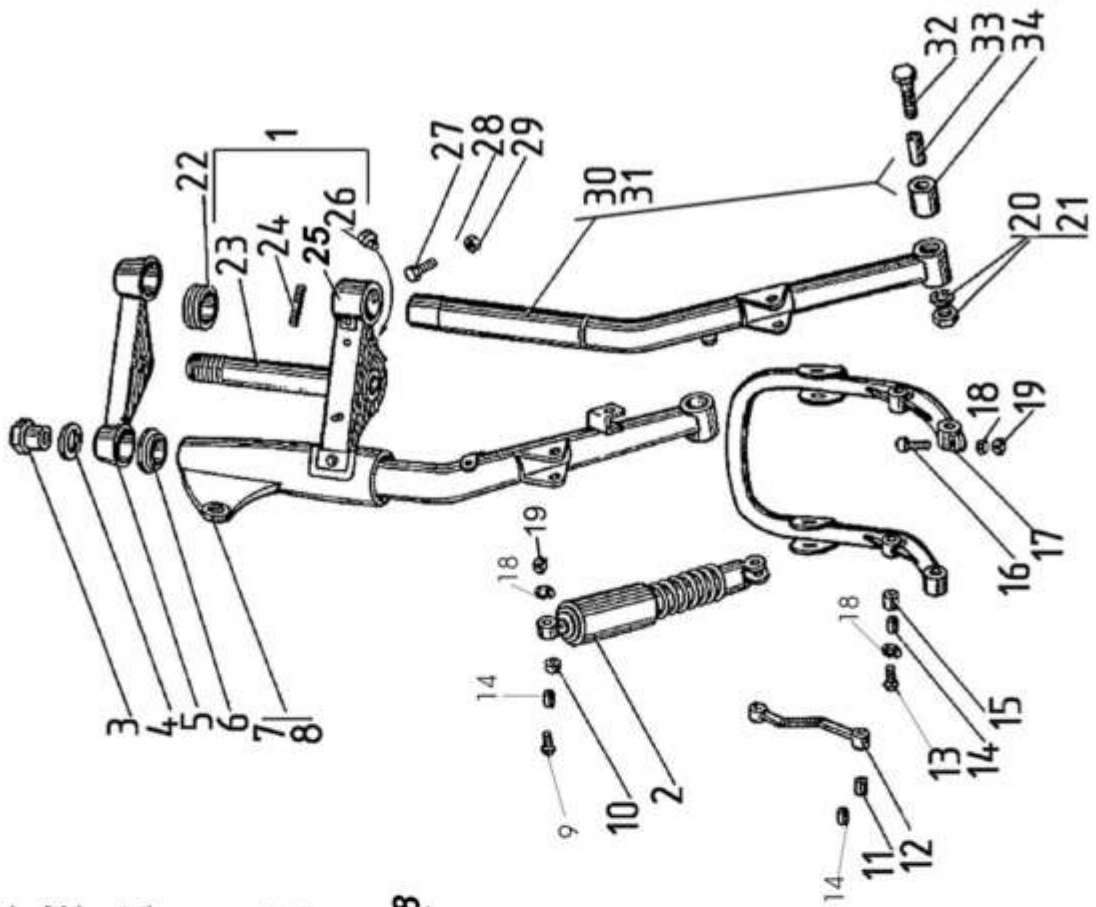
Fig. 24



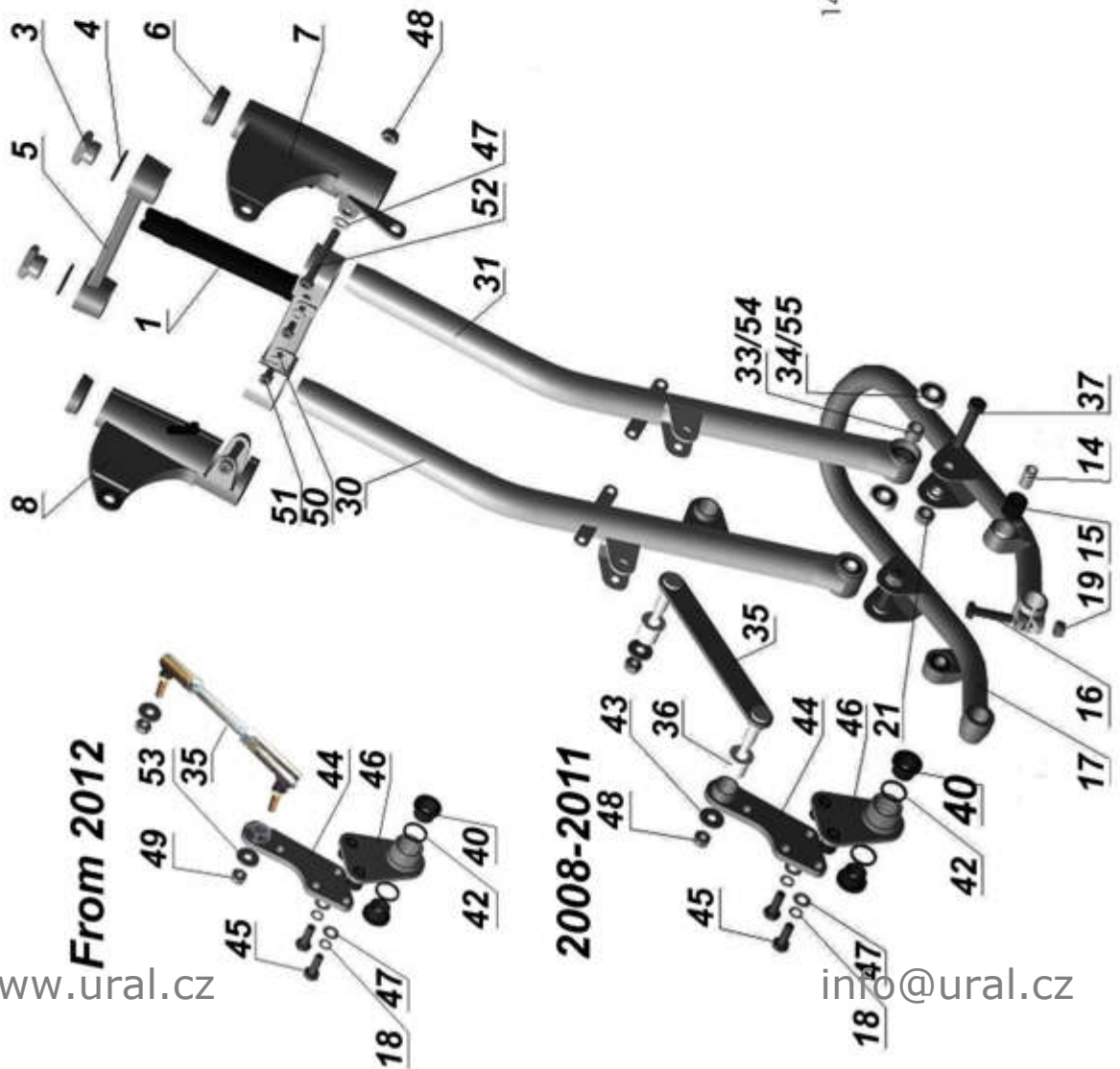
**Fig. 25**



**Until 2006**



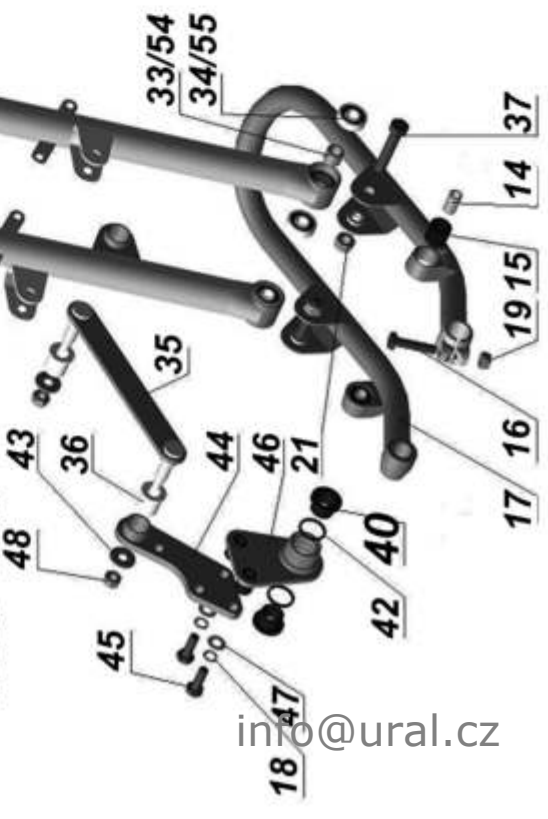
**From 2007**



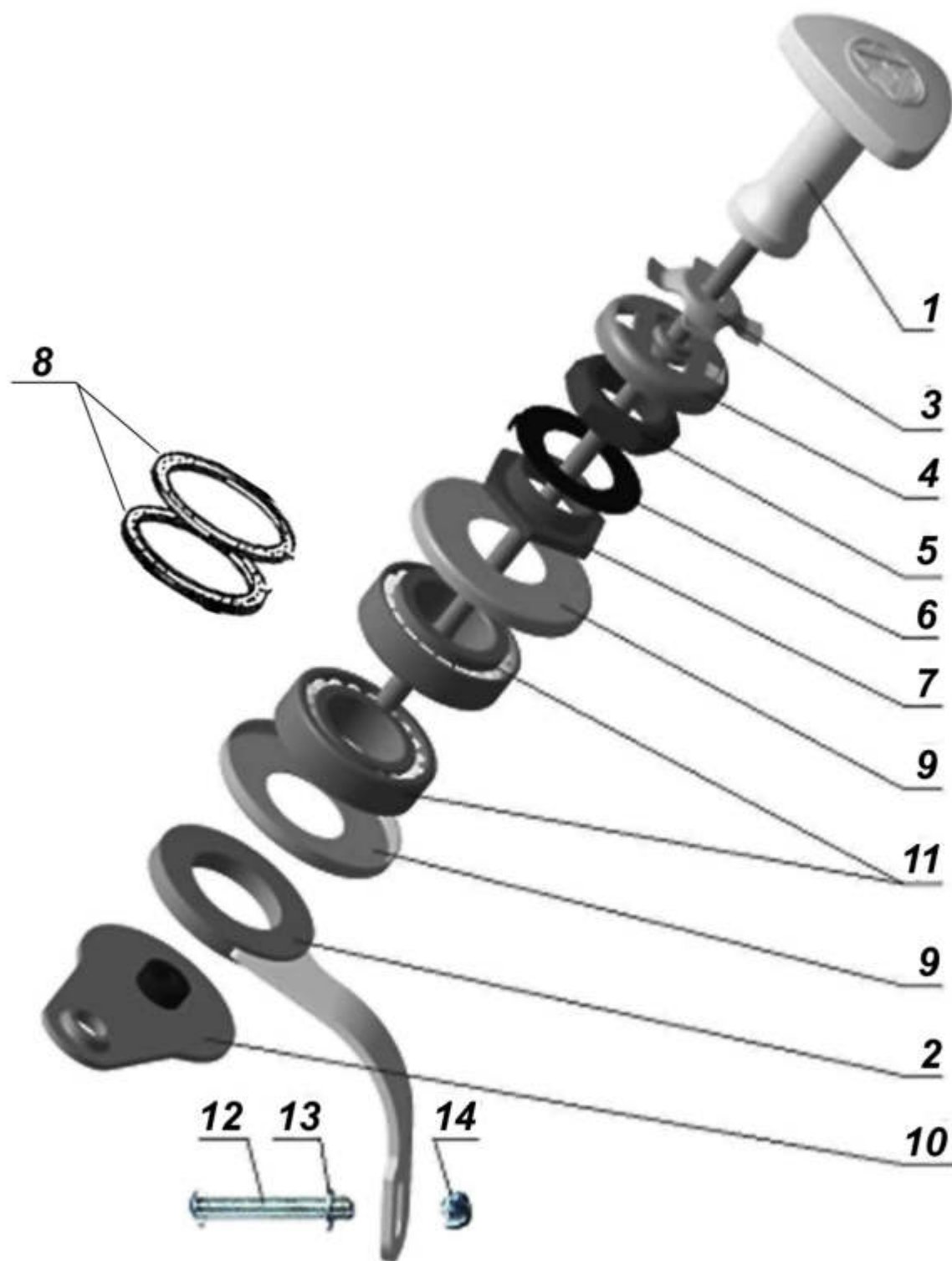
**From 2012**



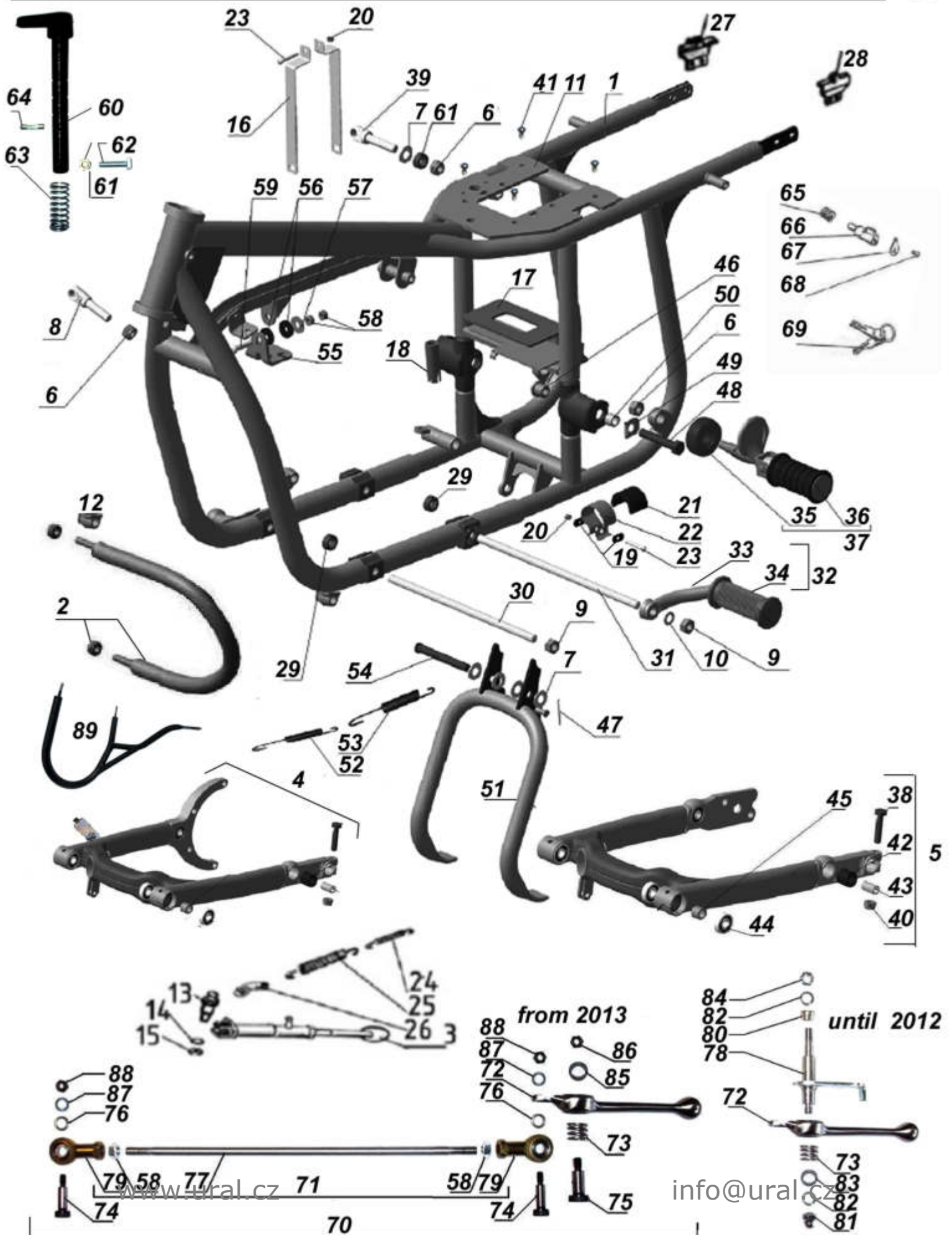
**2008-2011**



**Fig. 26**

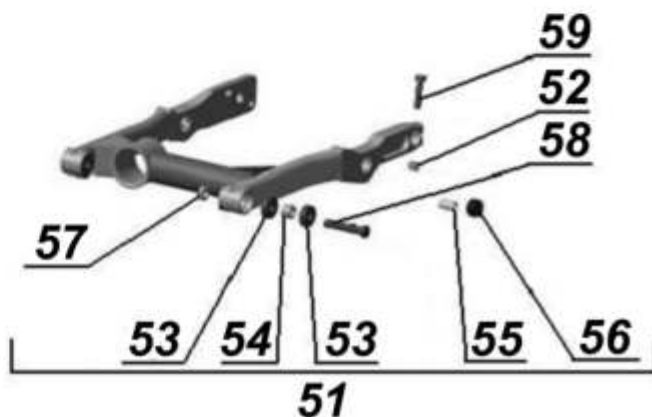
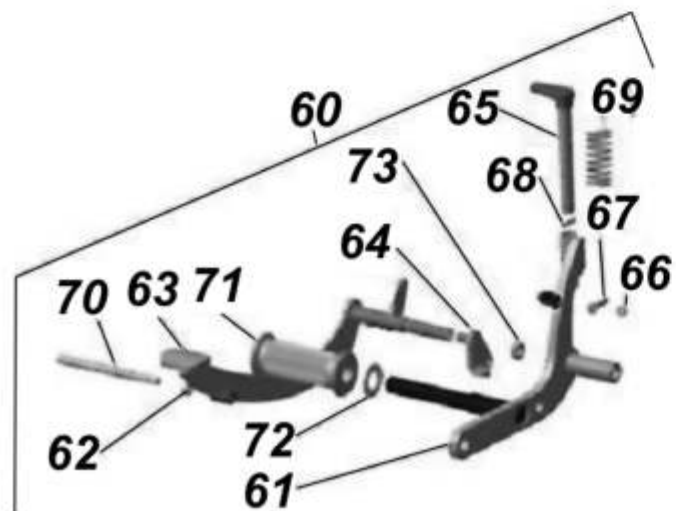
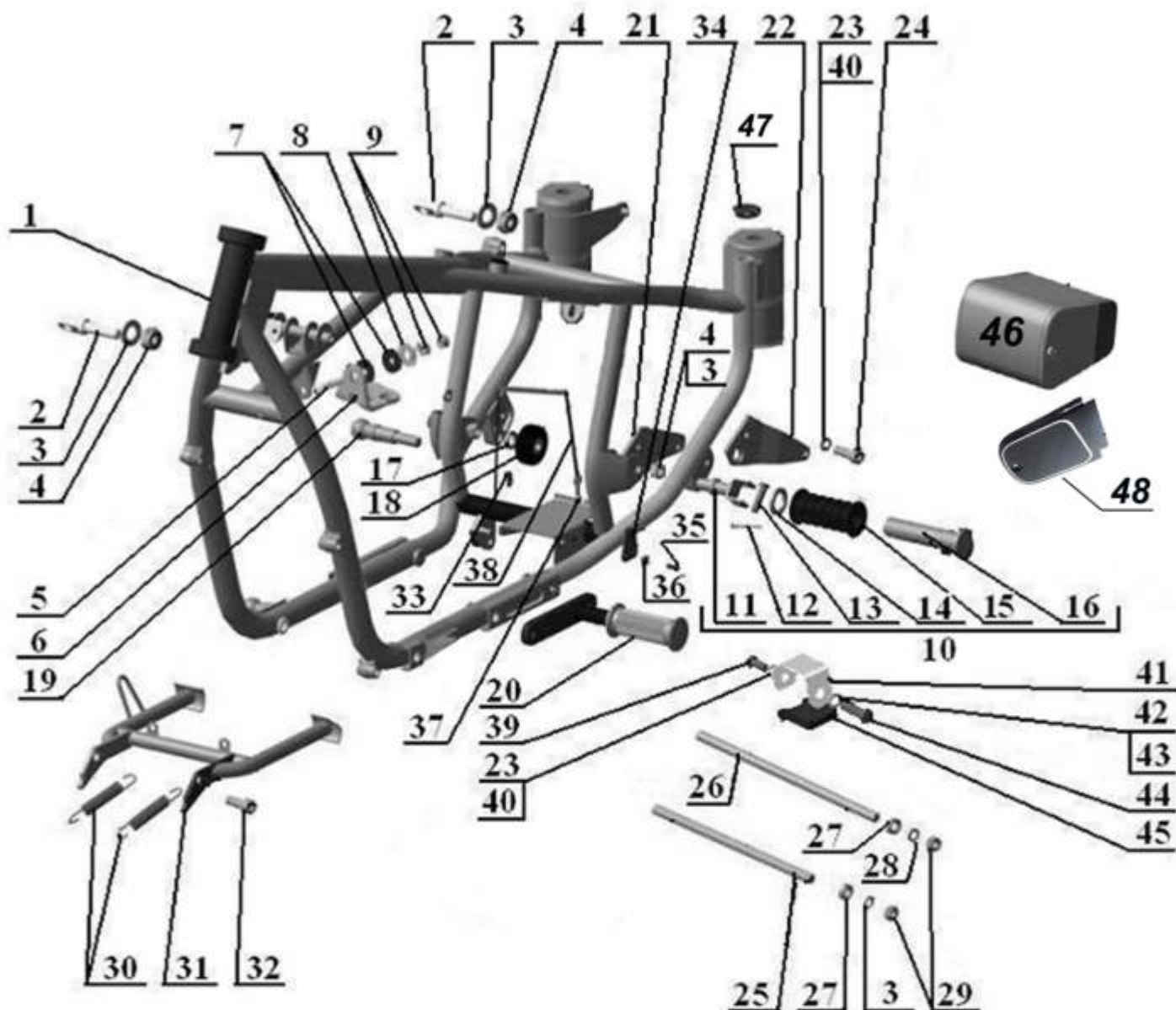


# Fig. 27

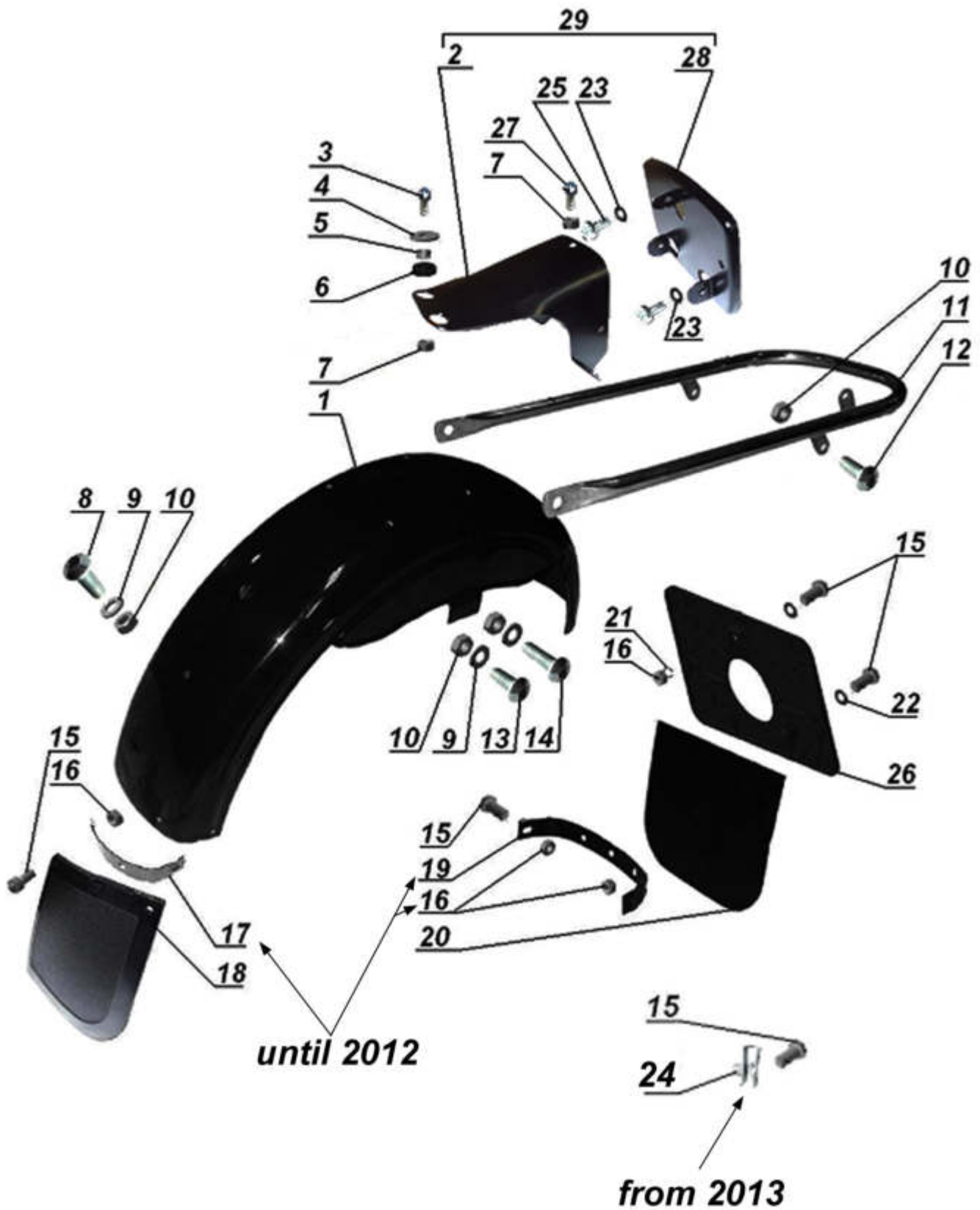




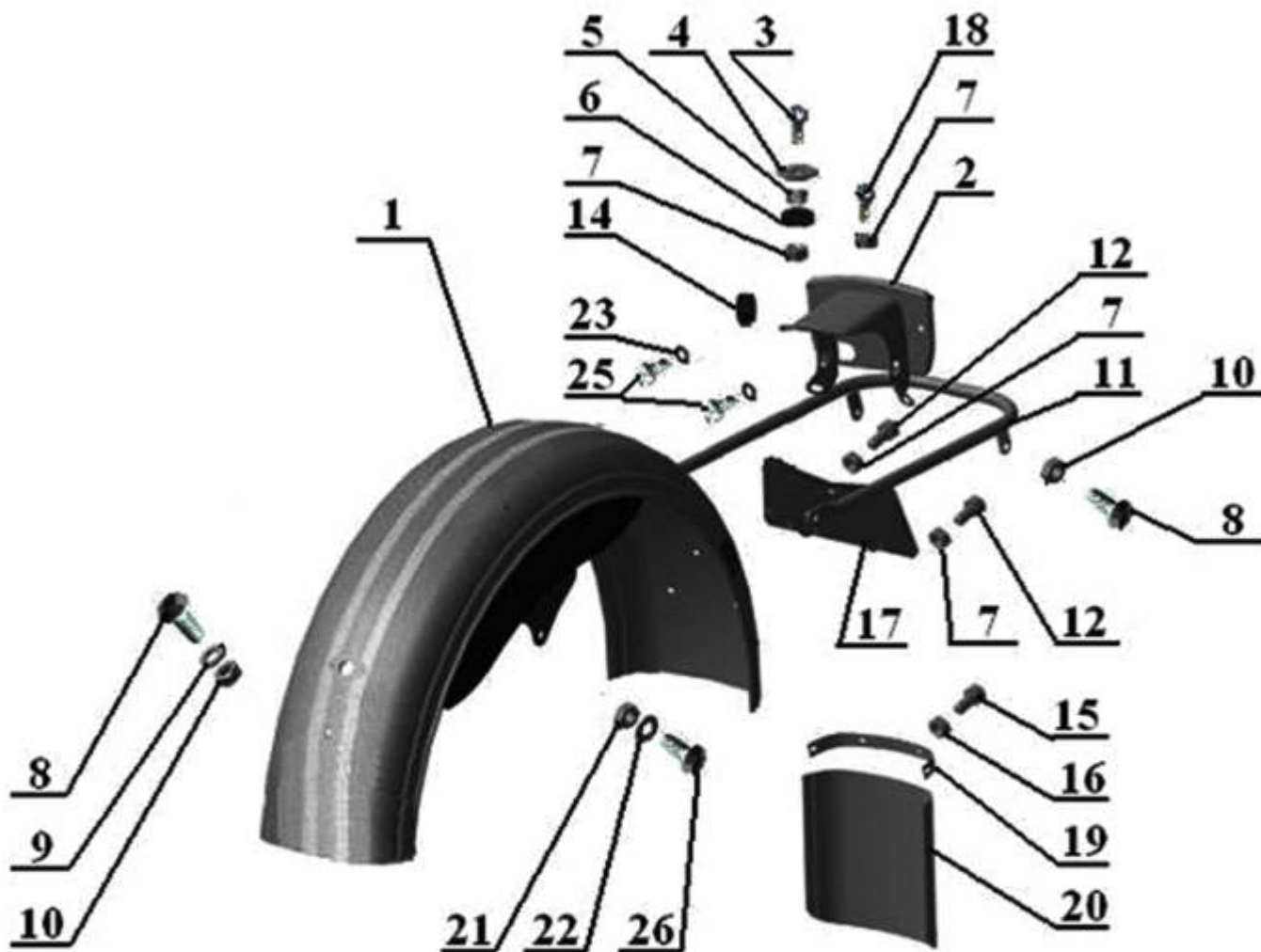
**Fig. 28**



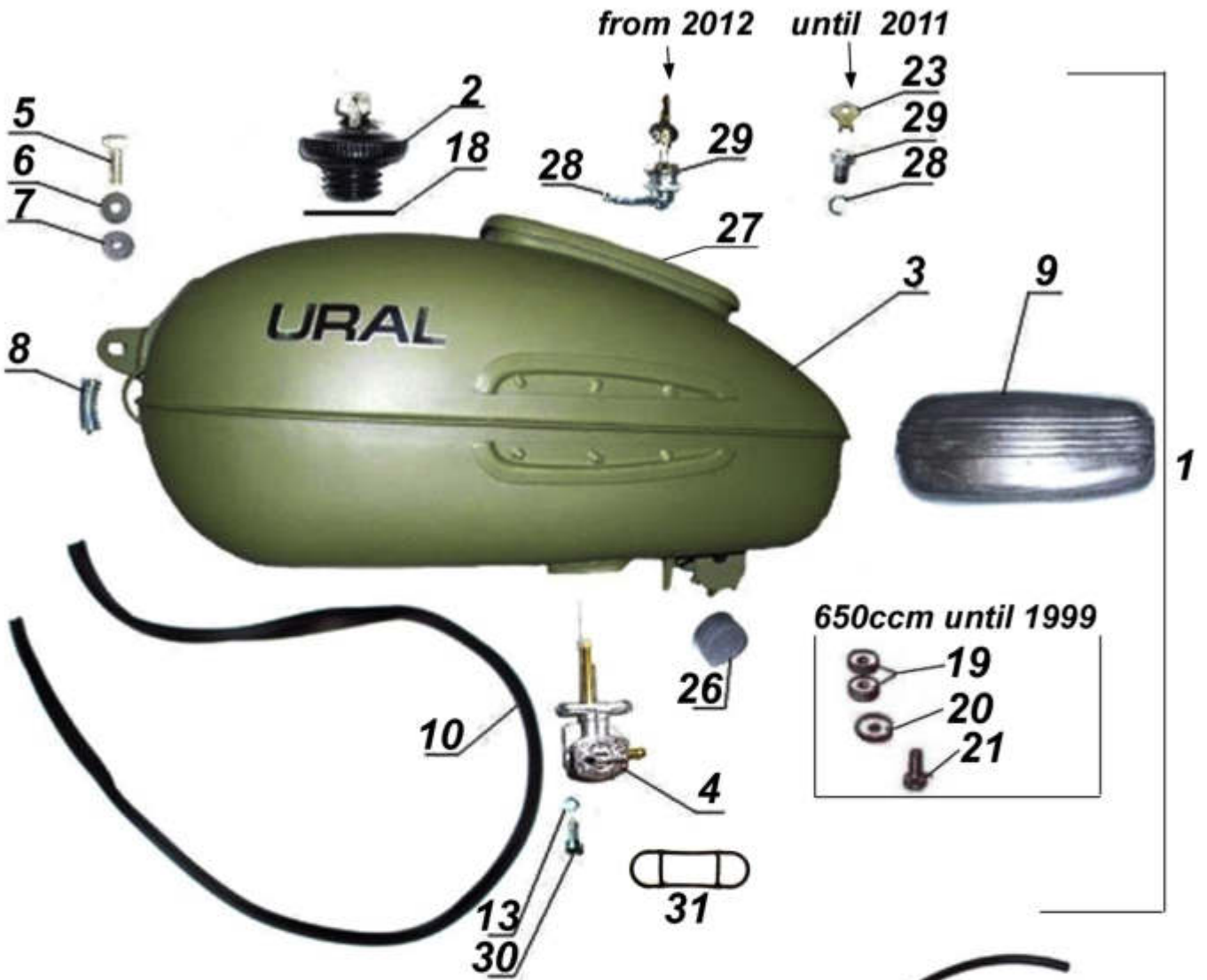
**Fig. 29.01**



**Fig. 29.02**



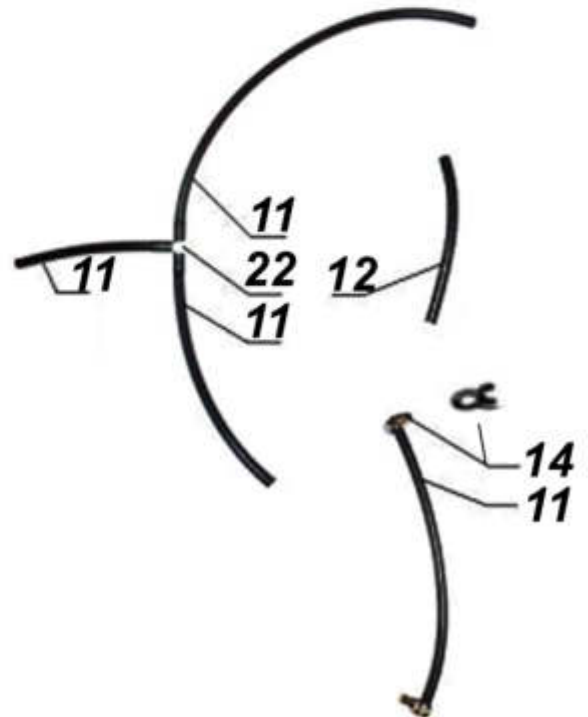
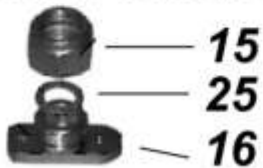
**Fig. 30.01**



**Fuel filter 650ccm**

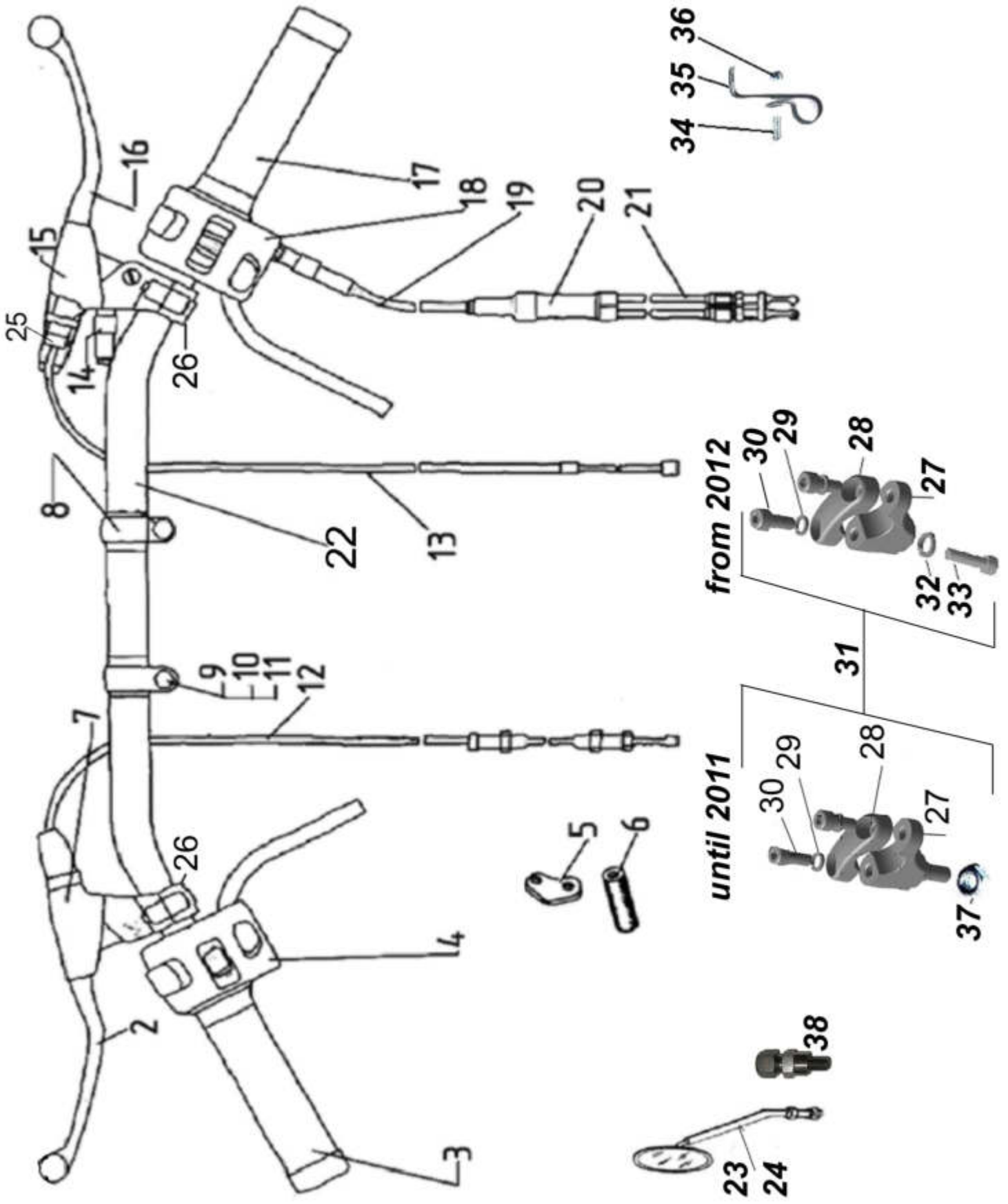


**Adapter KP33>Auto petcock**



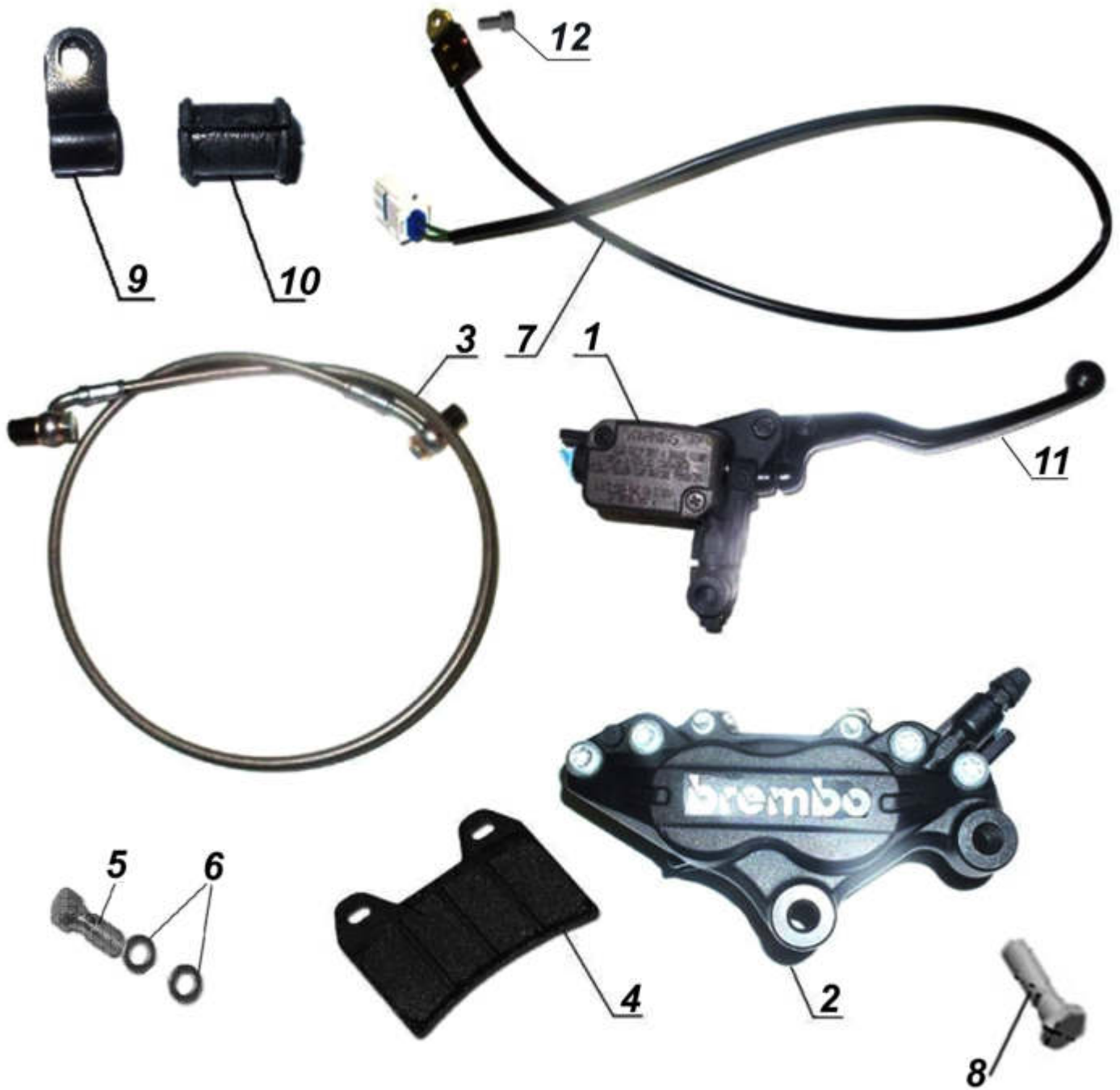


**Fig. 31**





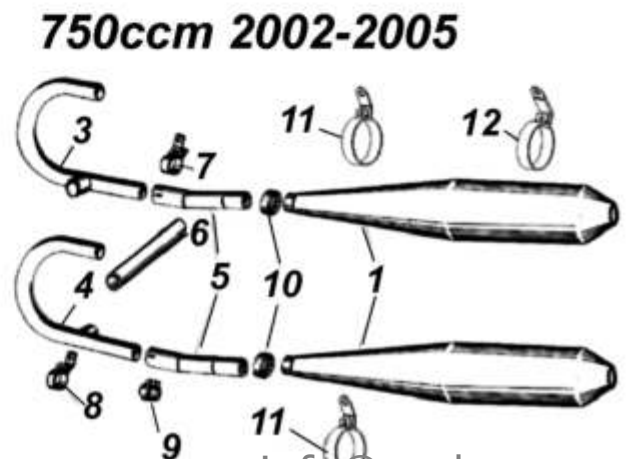
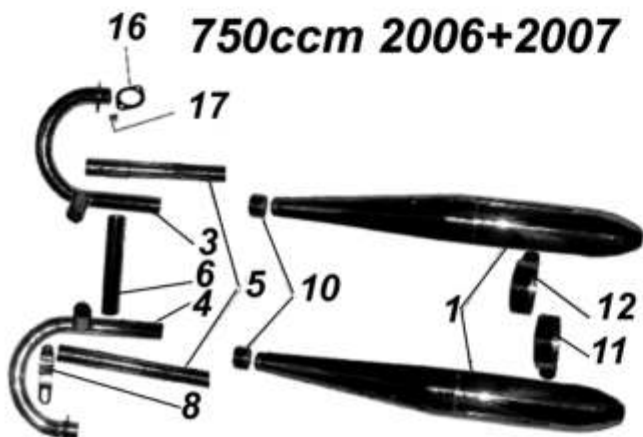
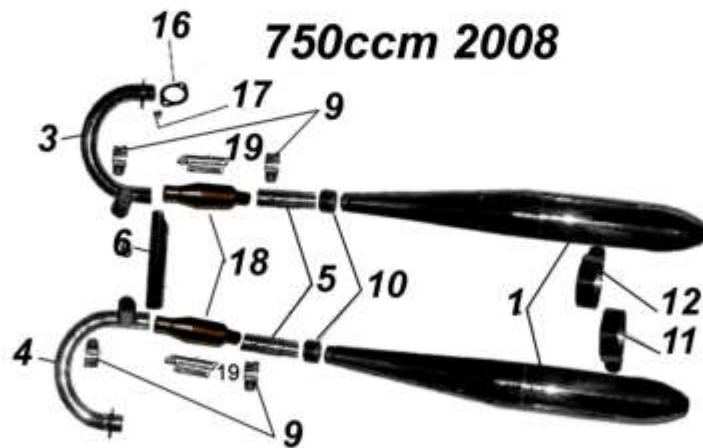
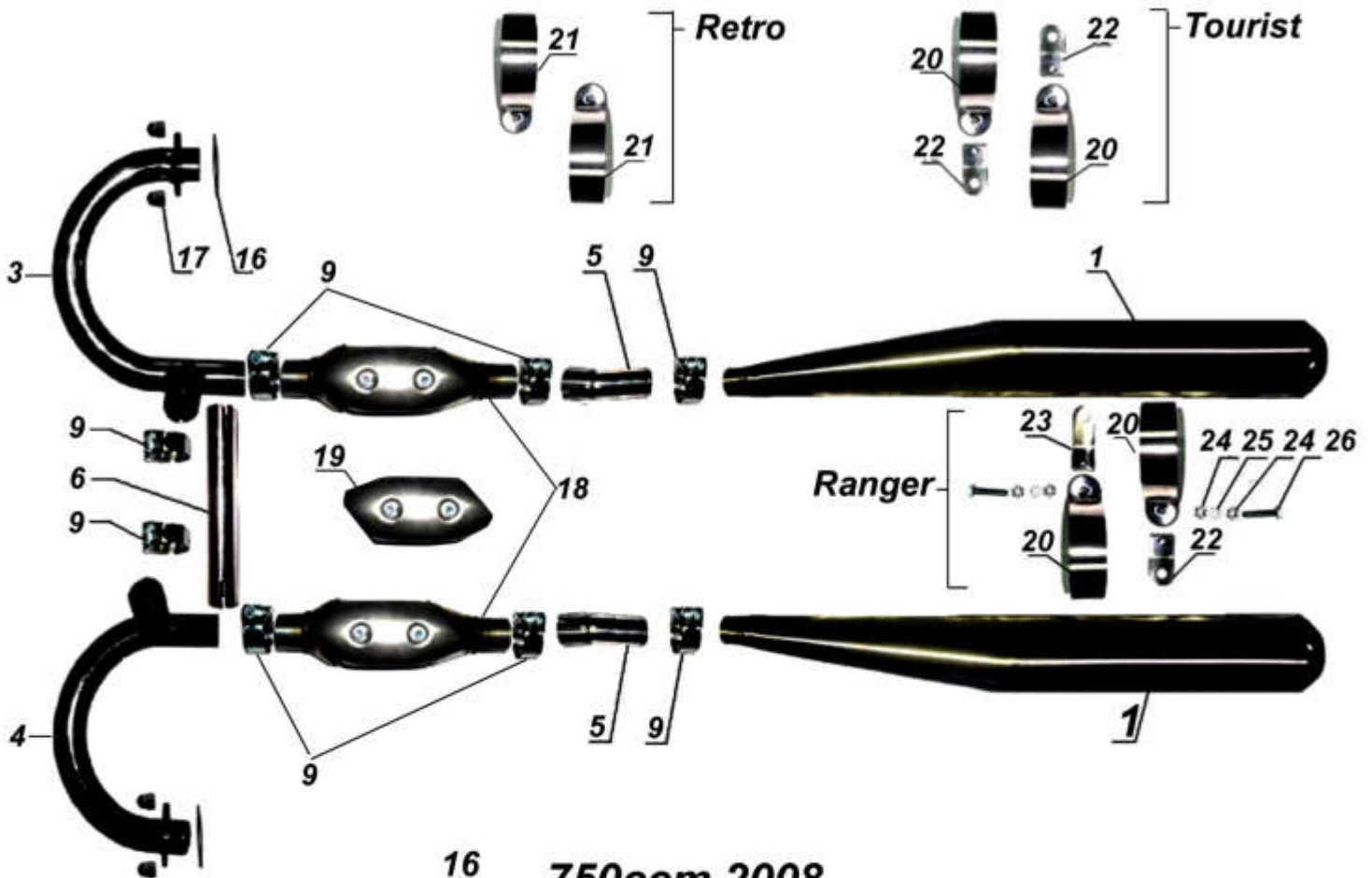
**Fig. 33**



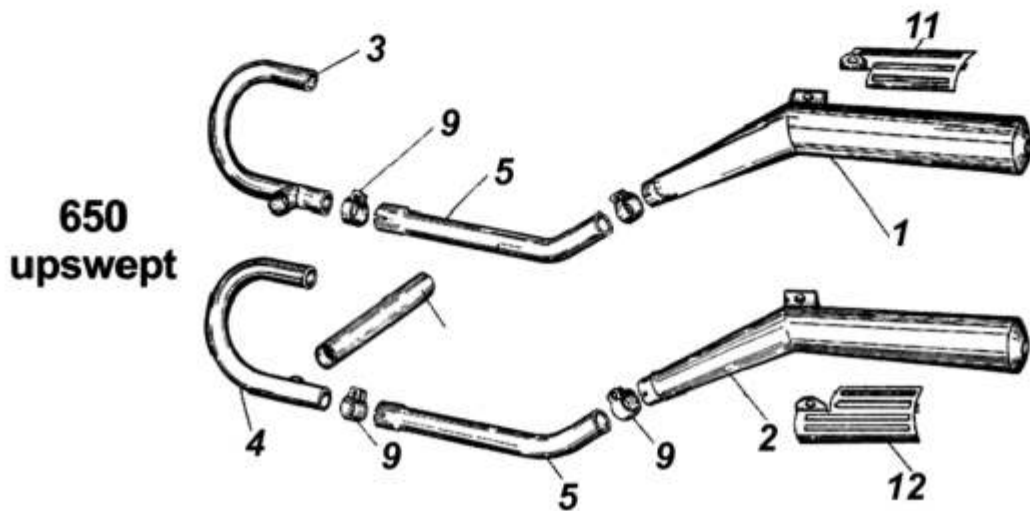
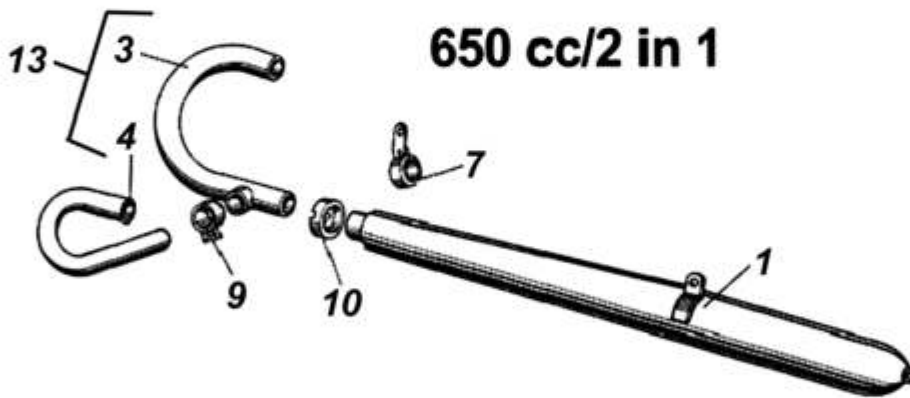
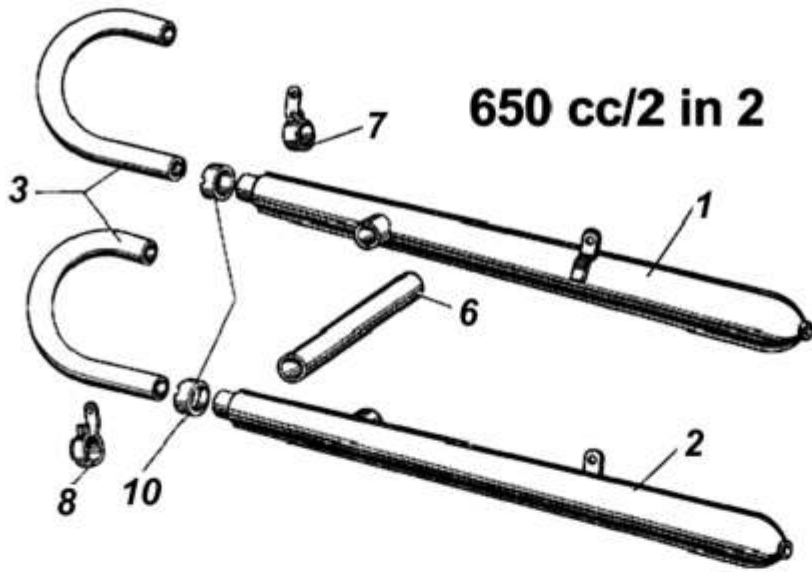


# Fig. 34.02

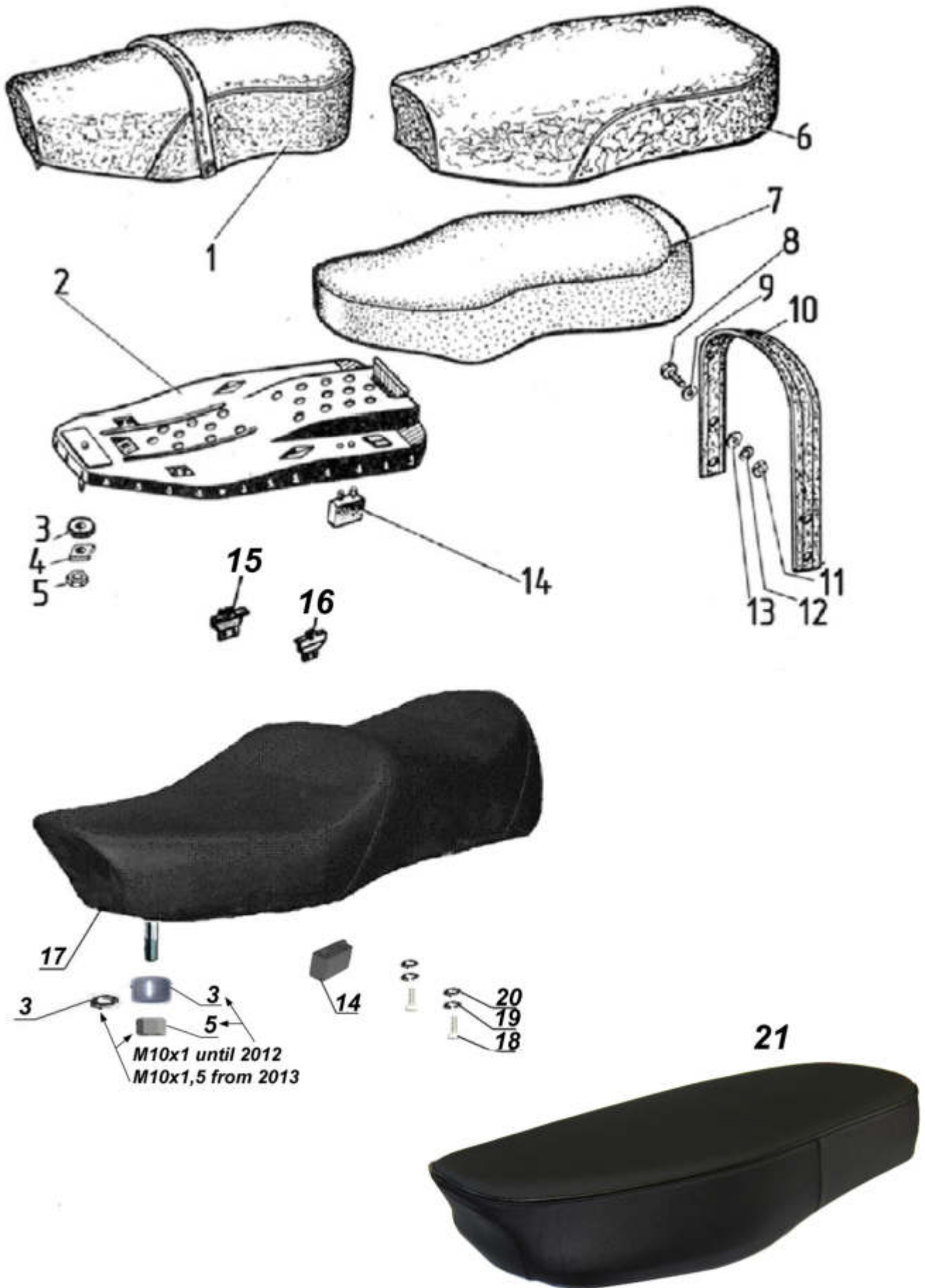
750ccm from 2009



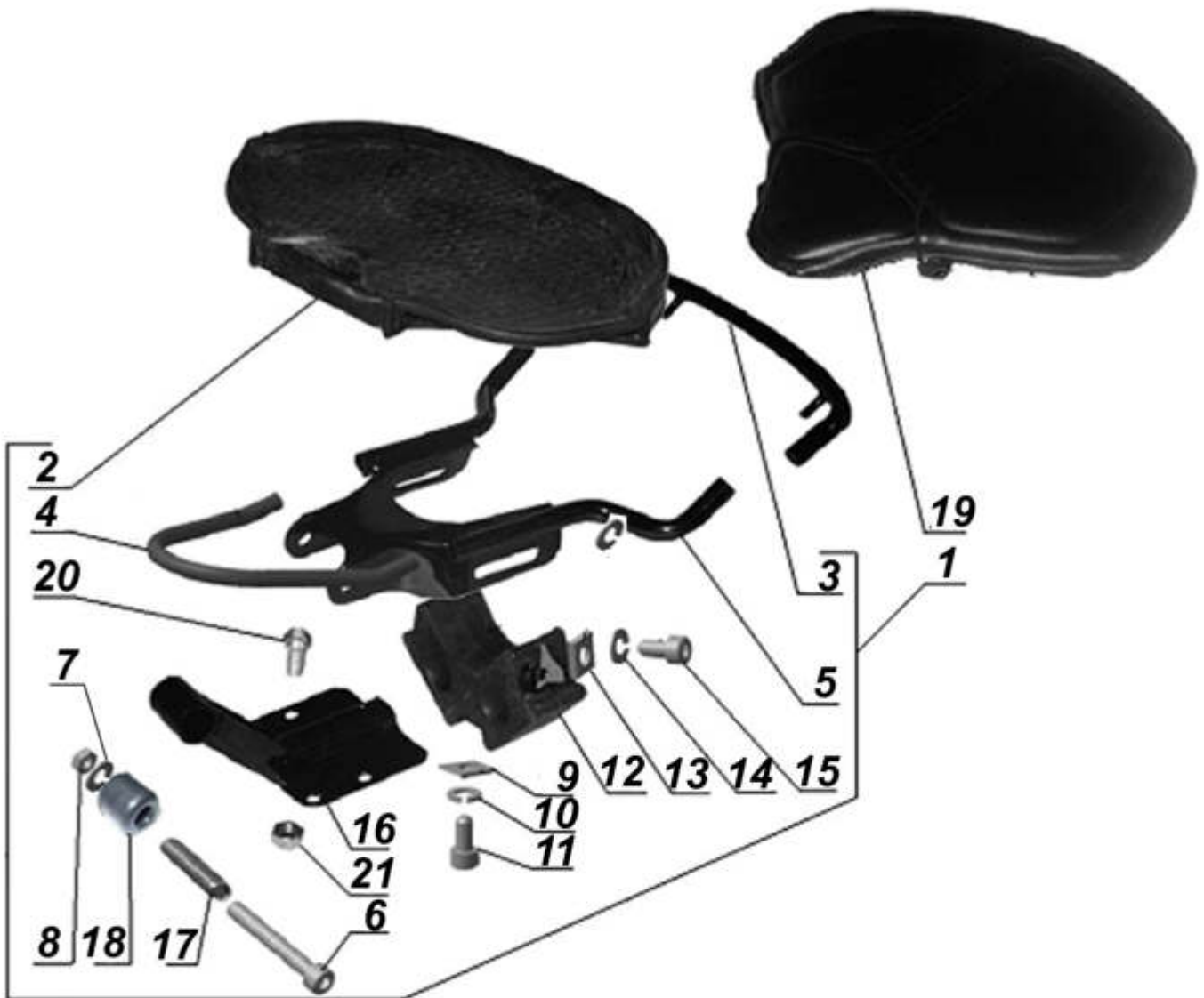
**Fig. 34.03**



**Fig. 35**



**Fig. 36**



**Special parts for Retro**



**Fig. 37**

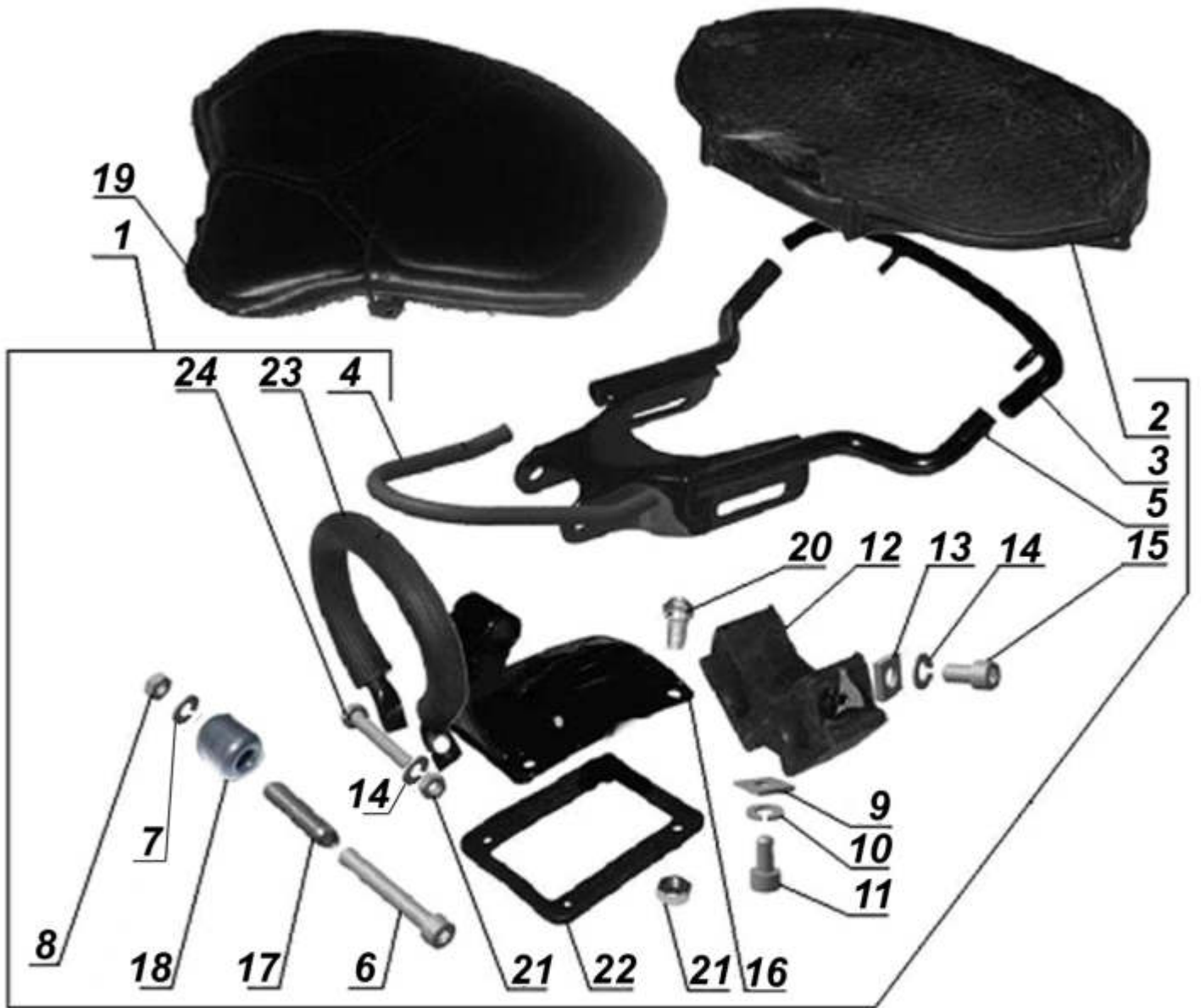
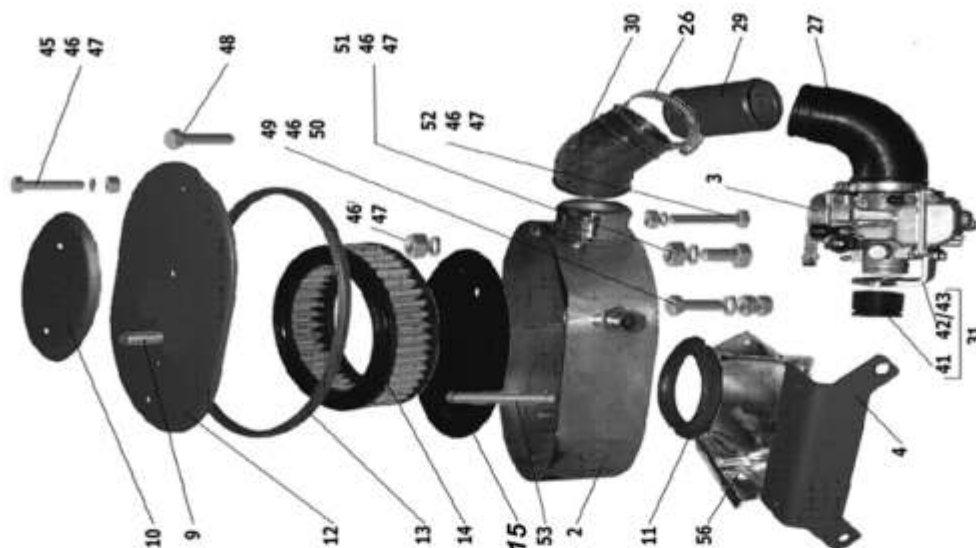


Fig. 38.01



2006 - 2007



Until 2005

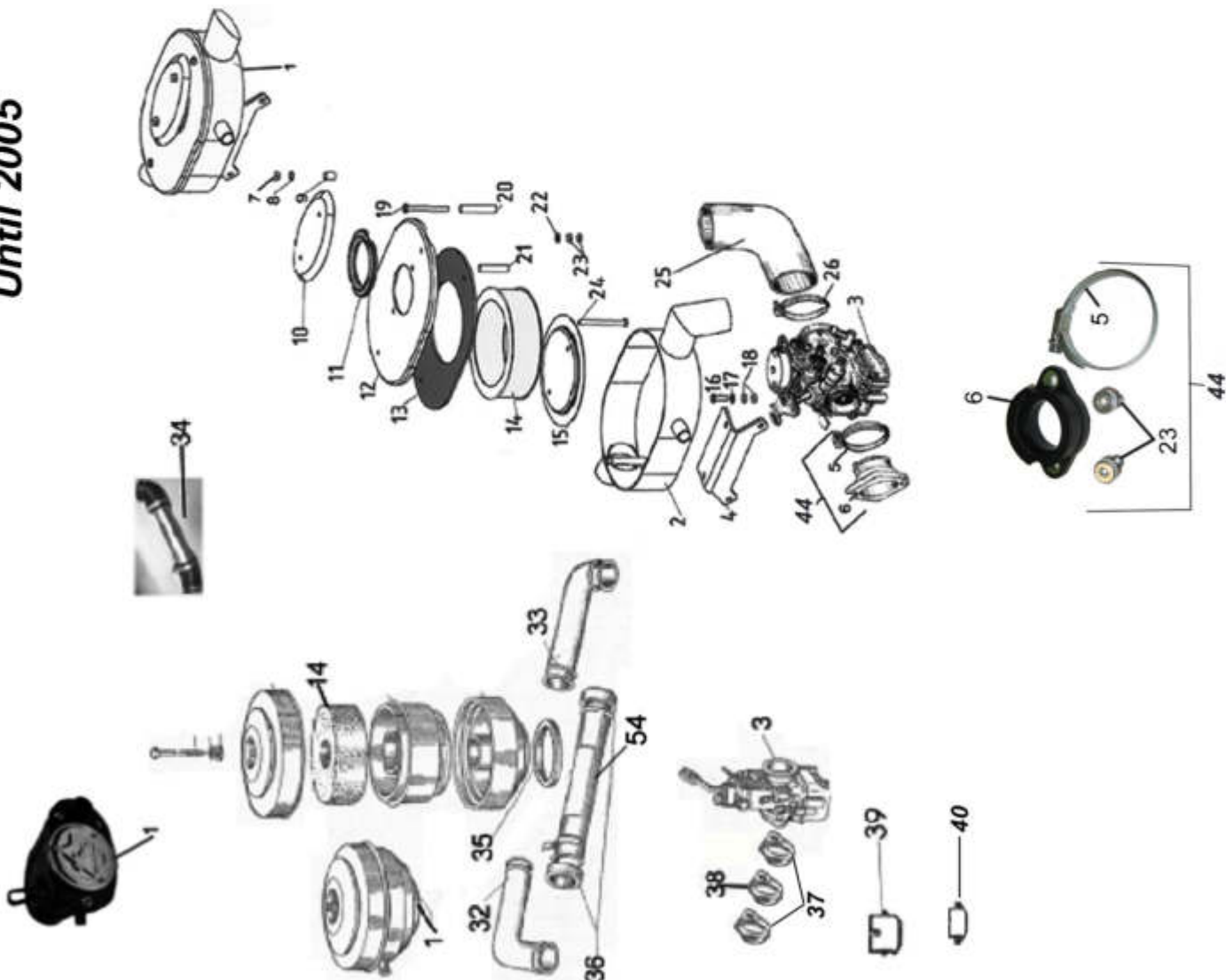
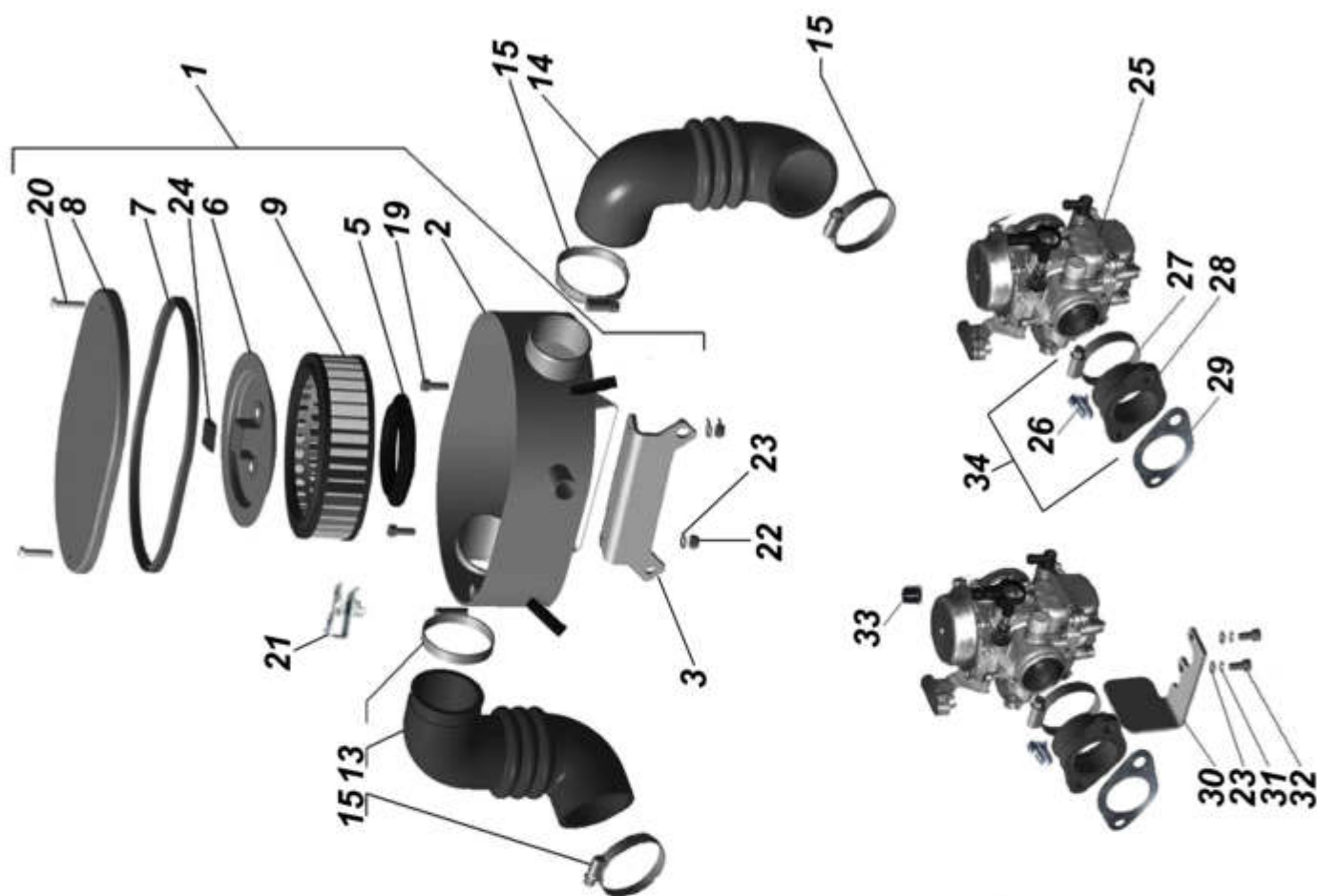


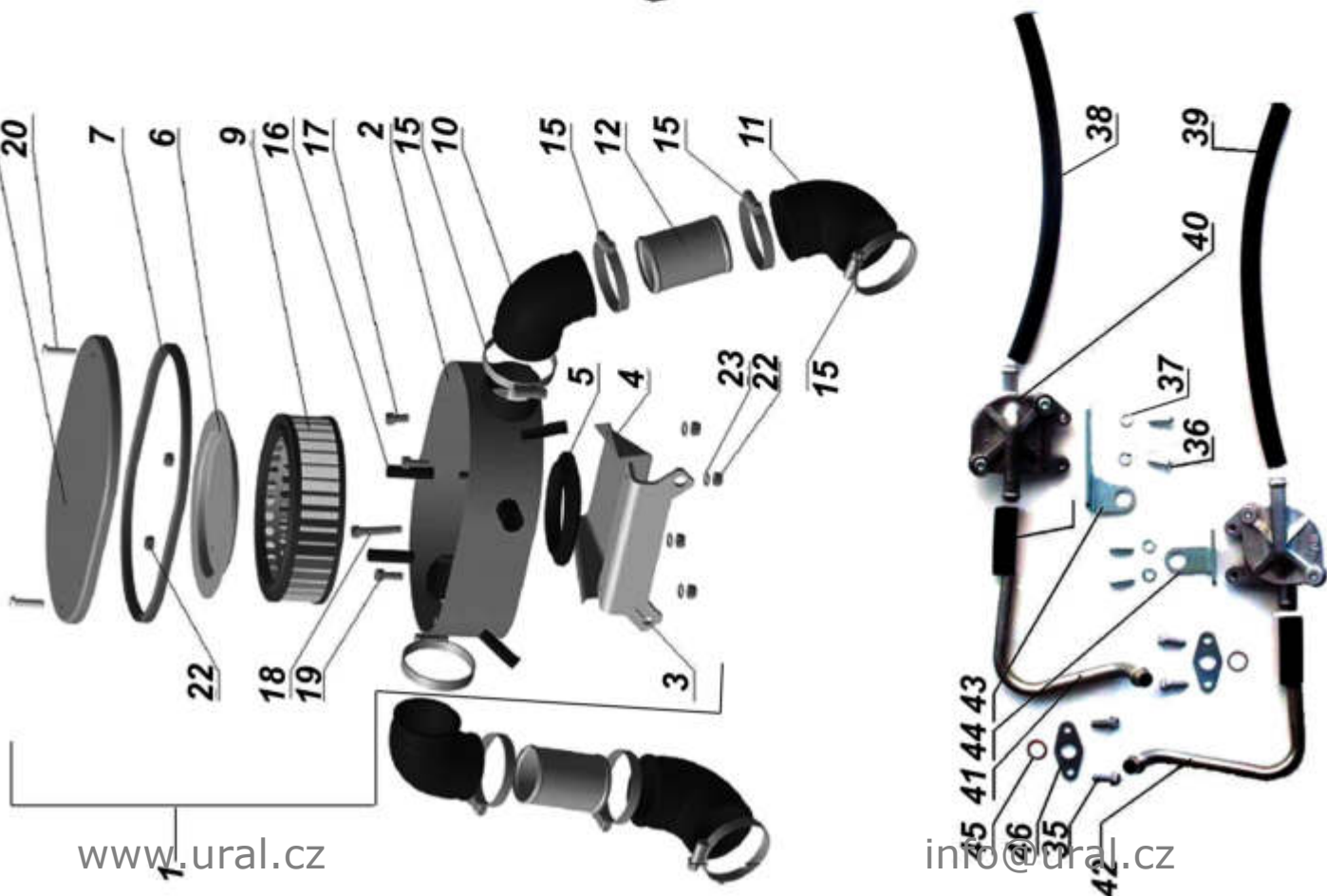
Fig. 38.02



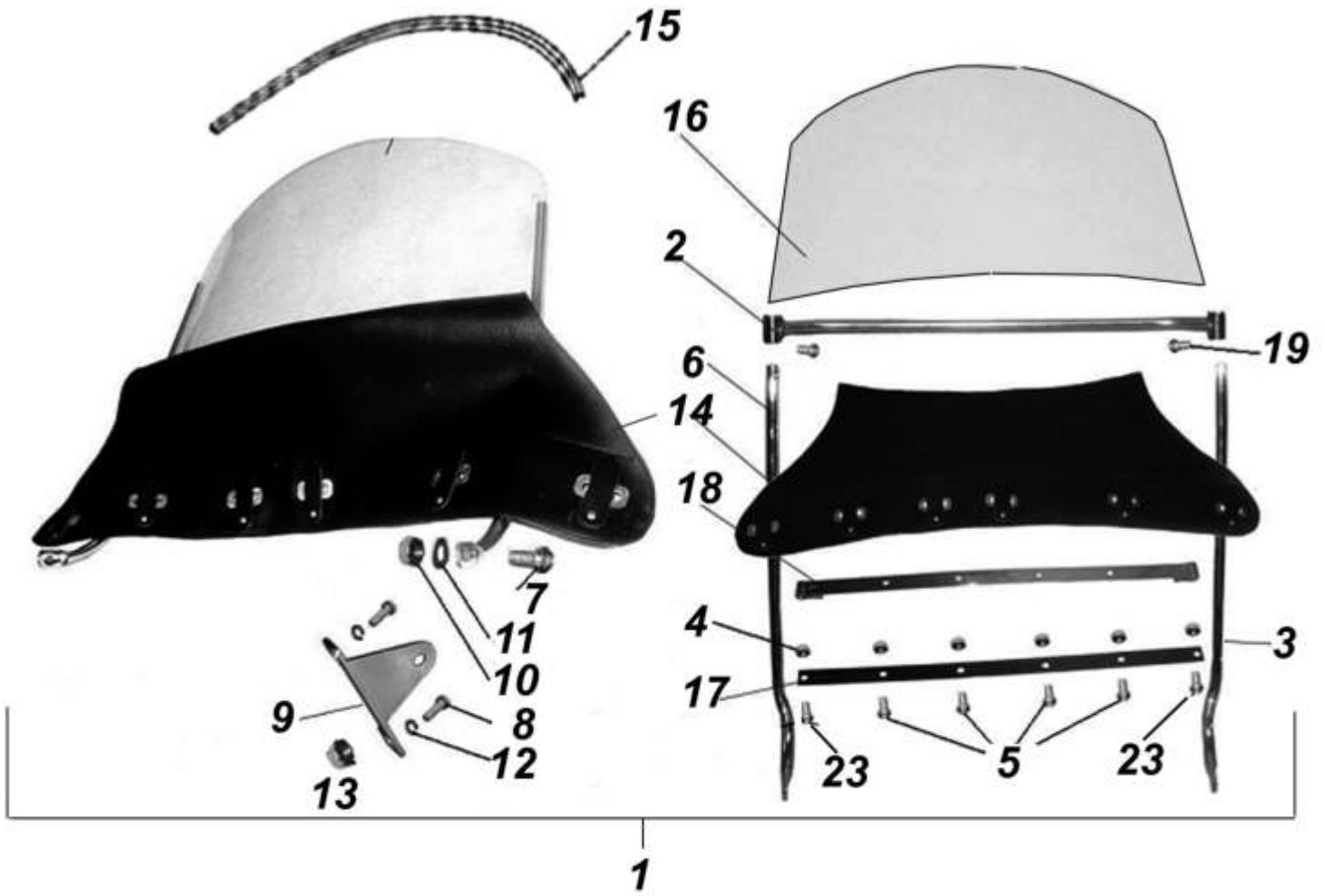
2013



2008 - 2012

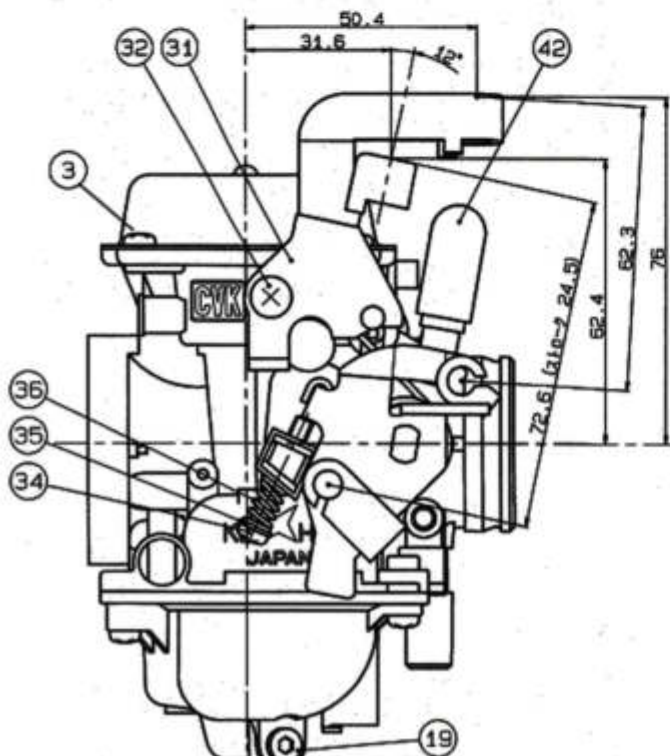
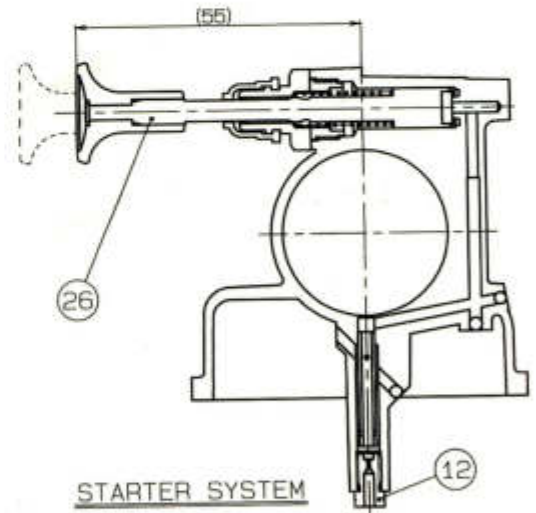
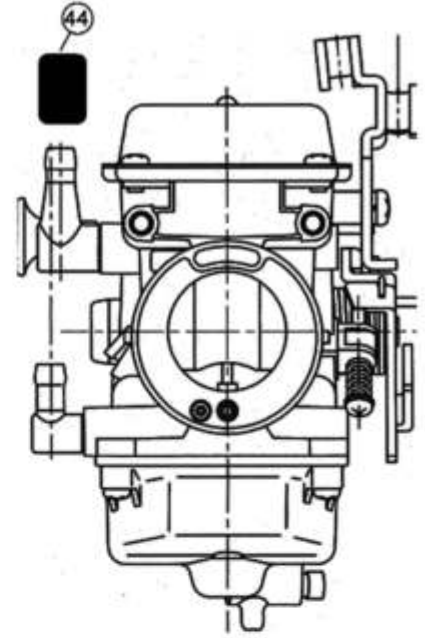
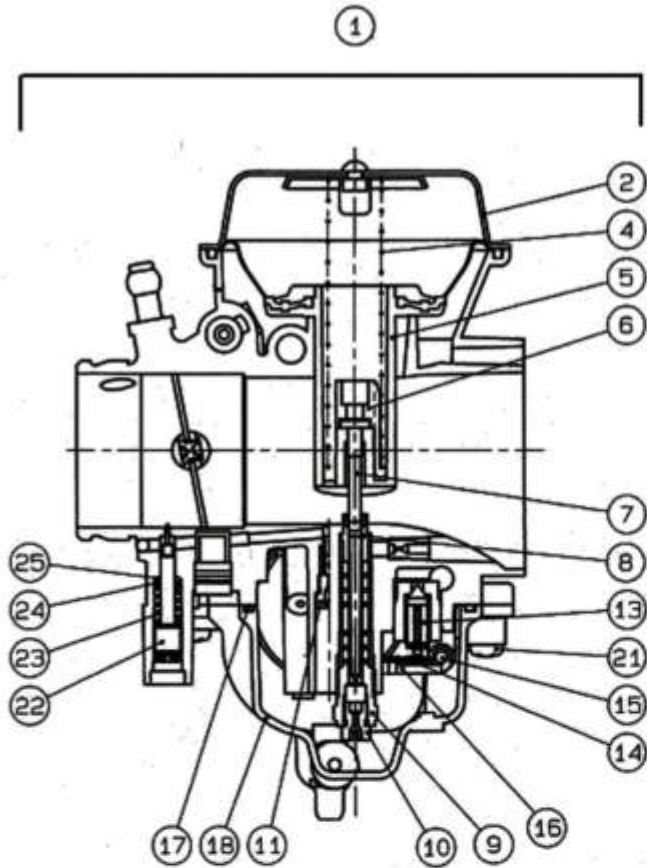


**Fig. 39**





**Fig. 40**



**45**

Fig. 41

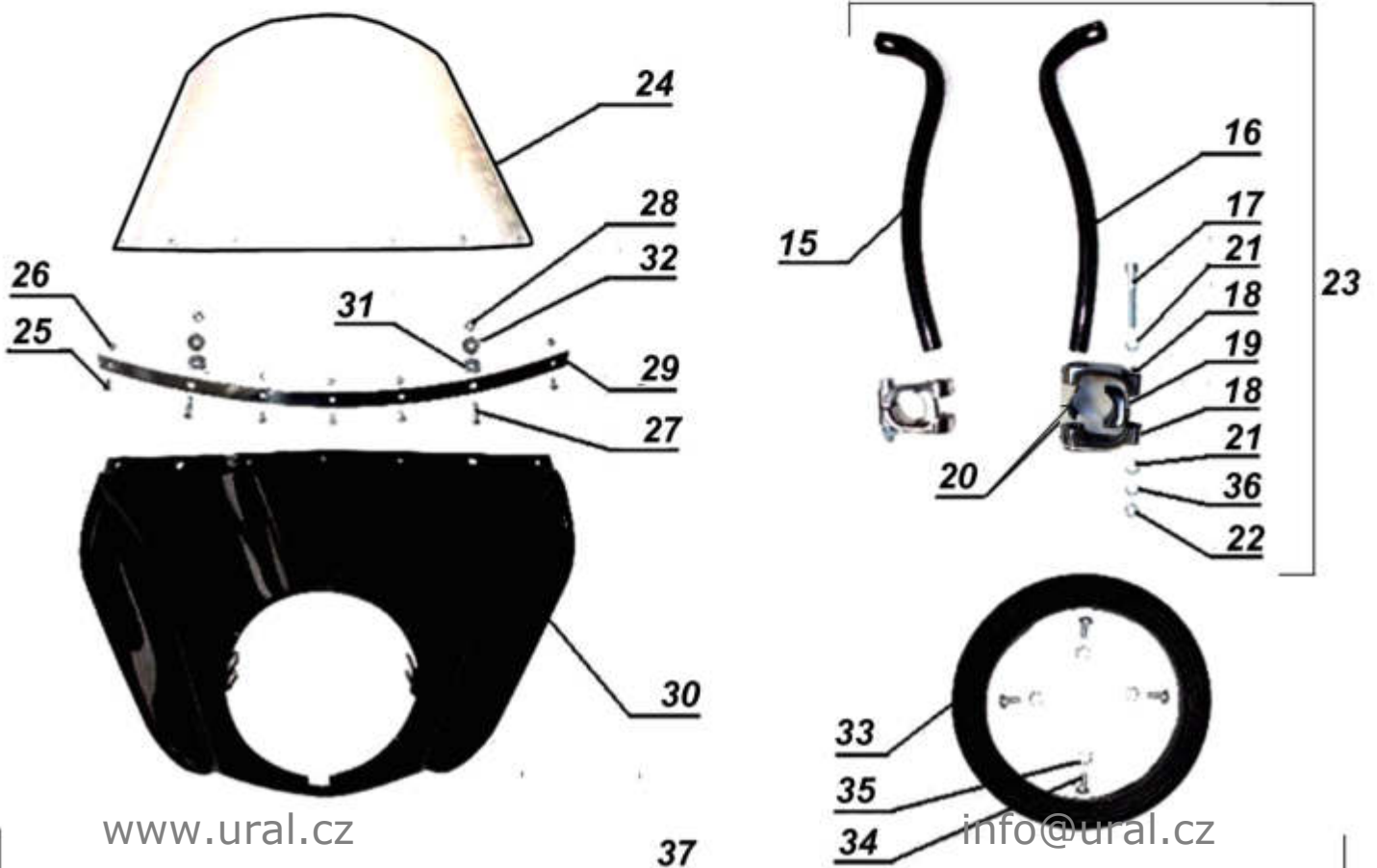
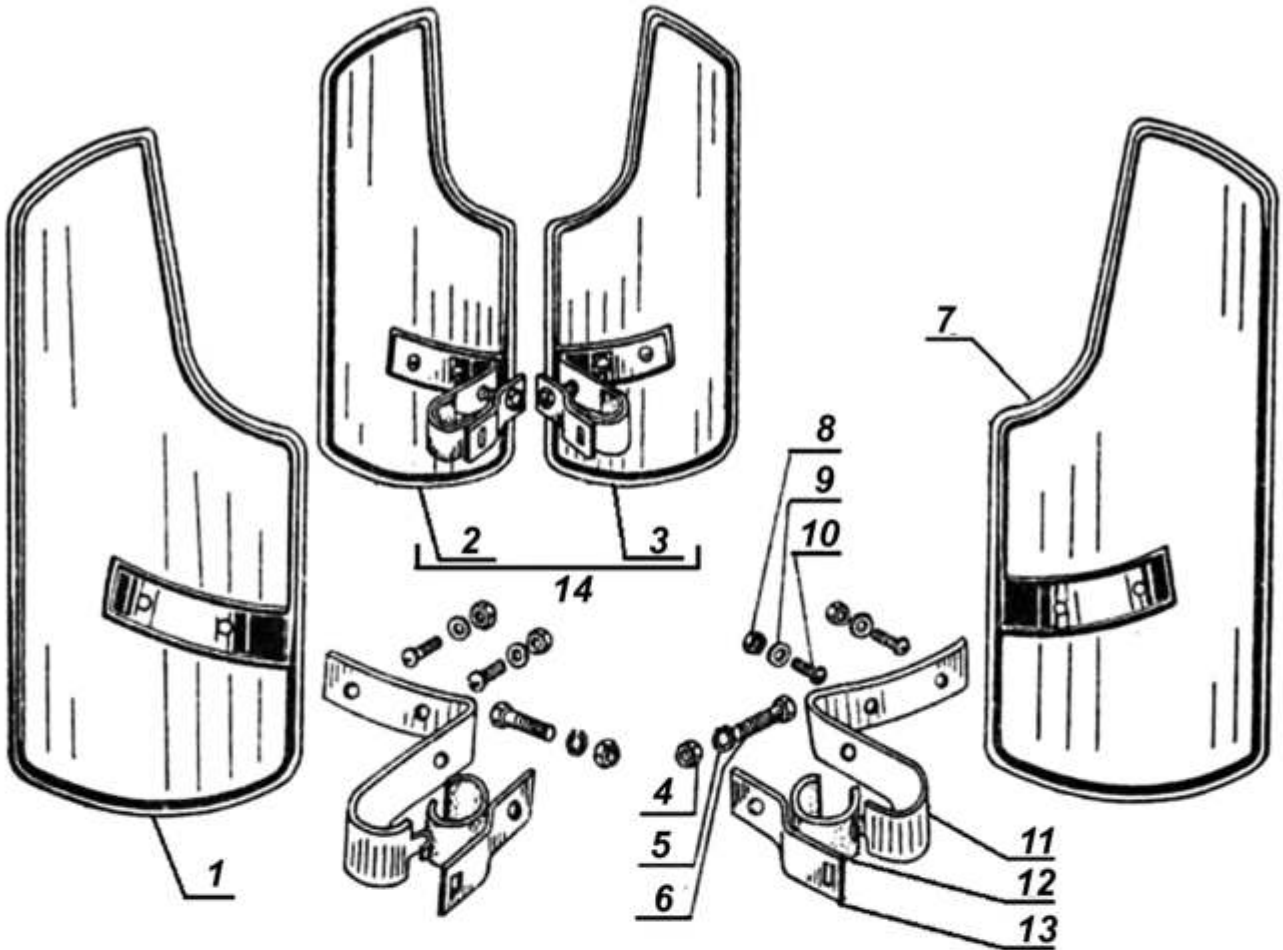


Fig. 42

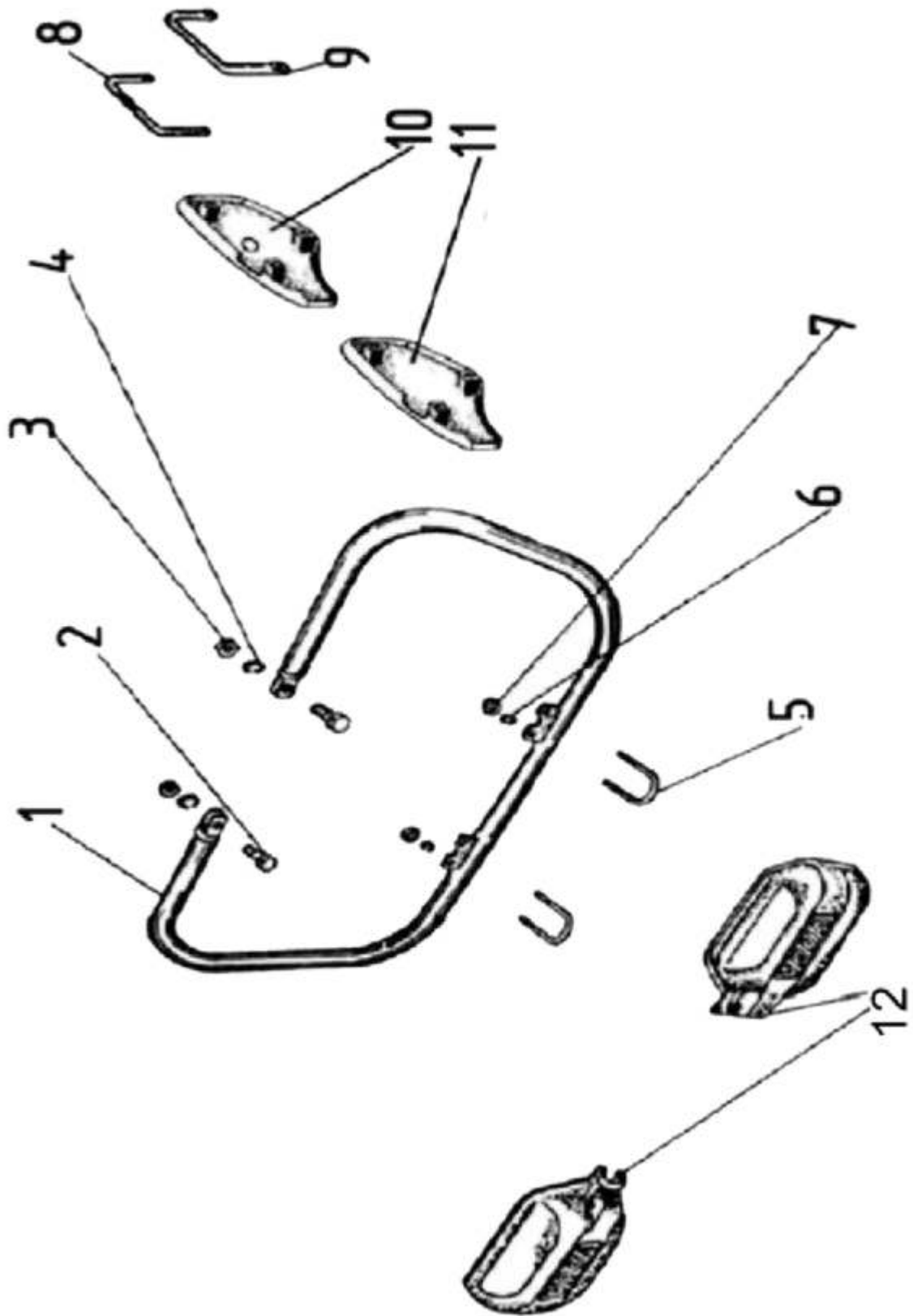


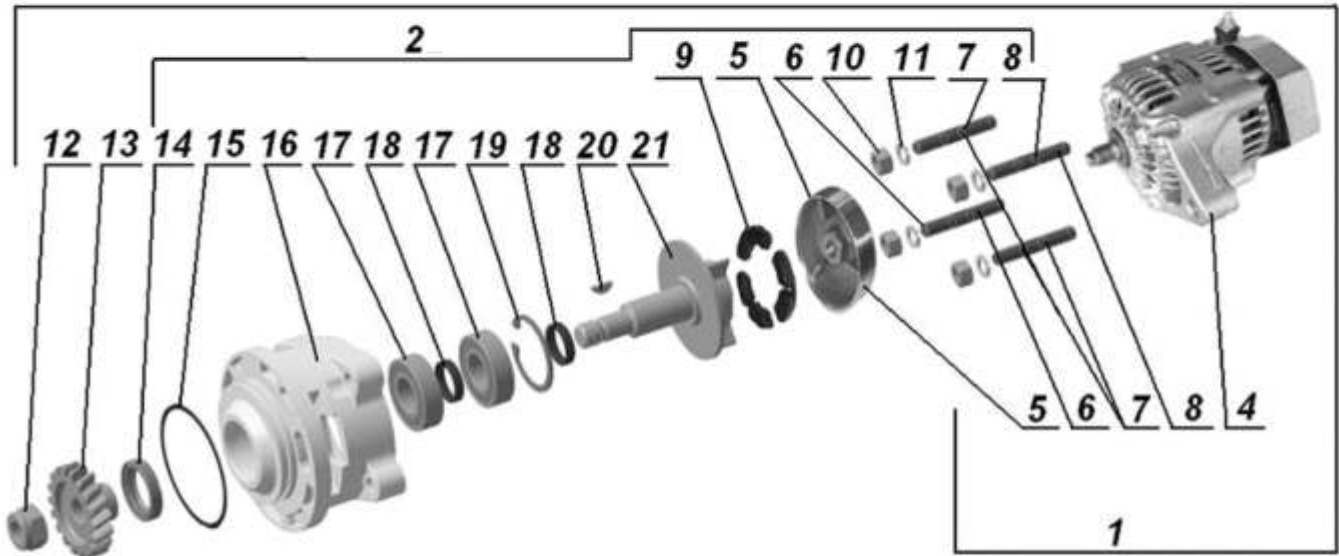
Fig. 43.01



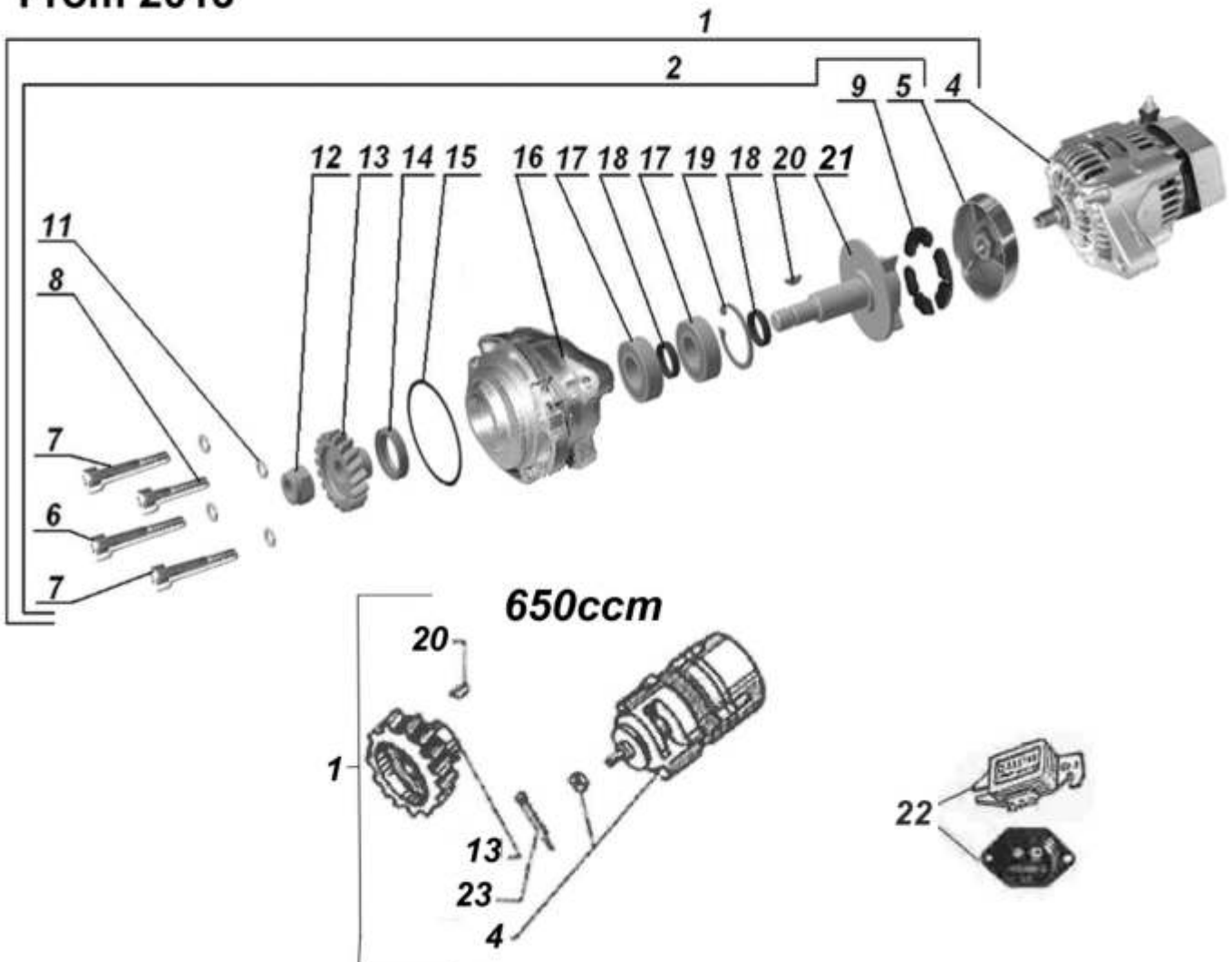
**Fig. 43.02**



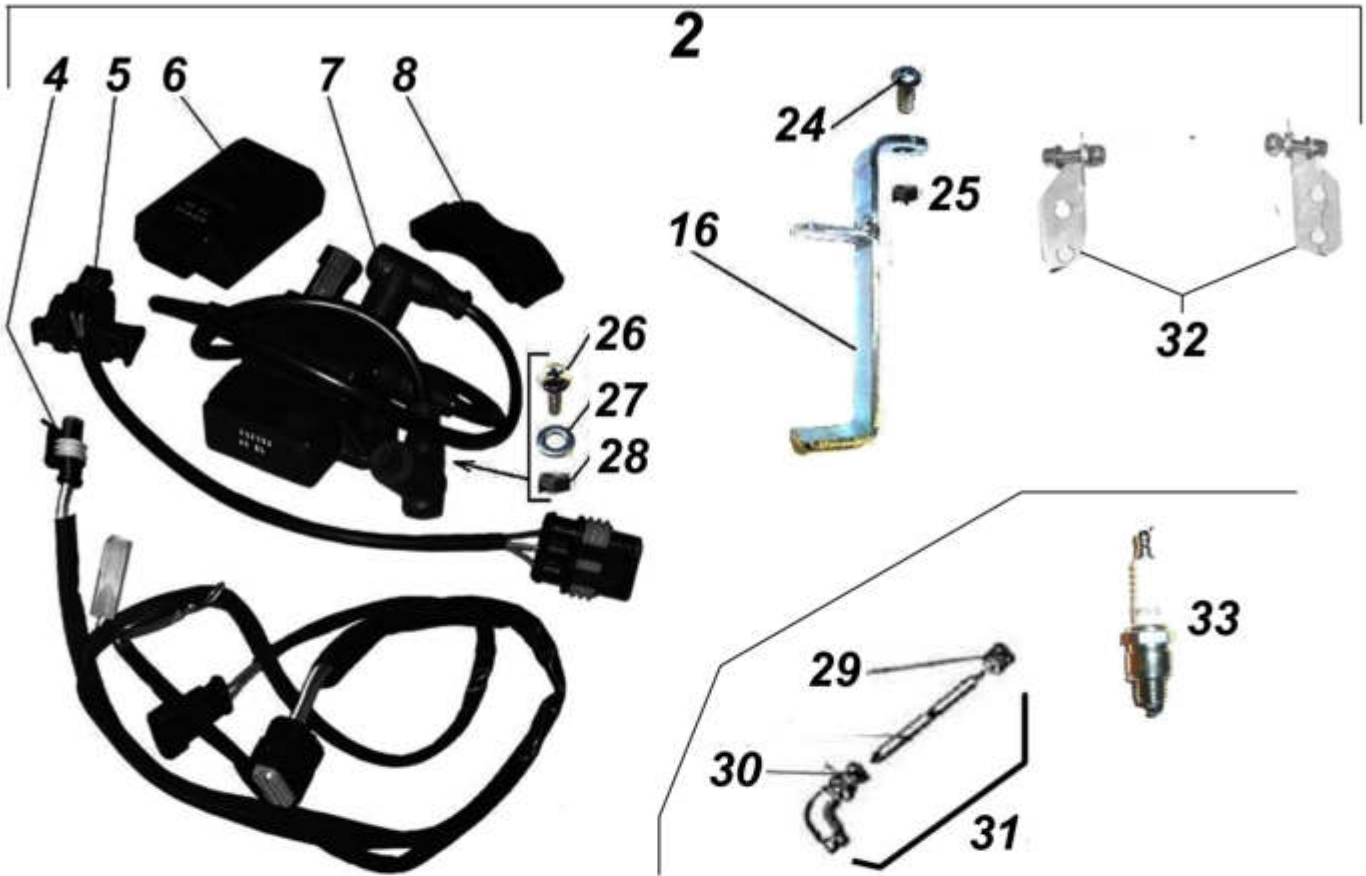
**Until 2012**



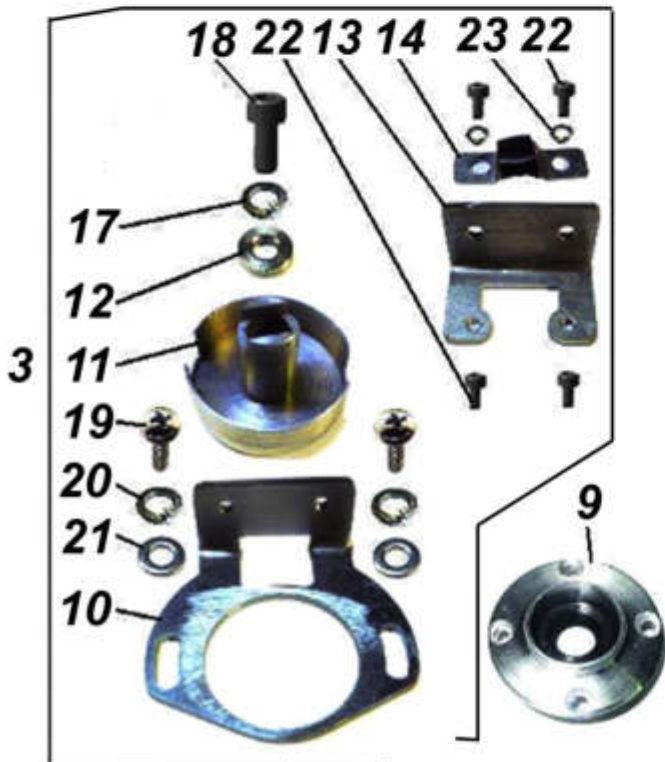
**From 2013**



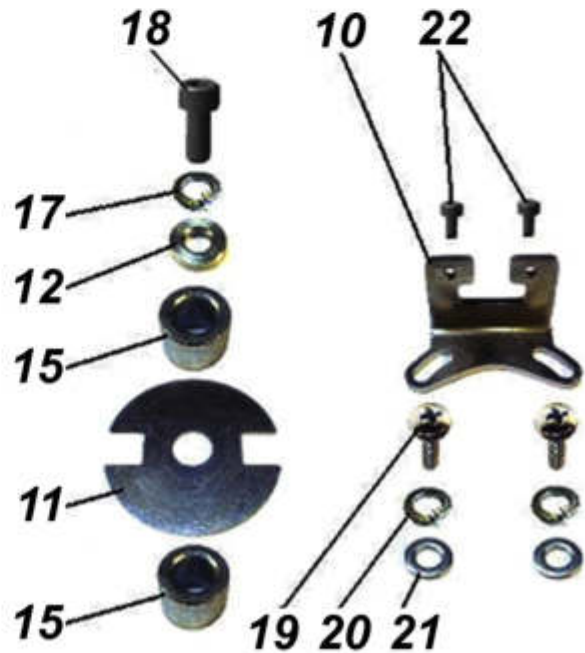
**Fig. 43.03**



**until 2011**



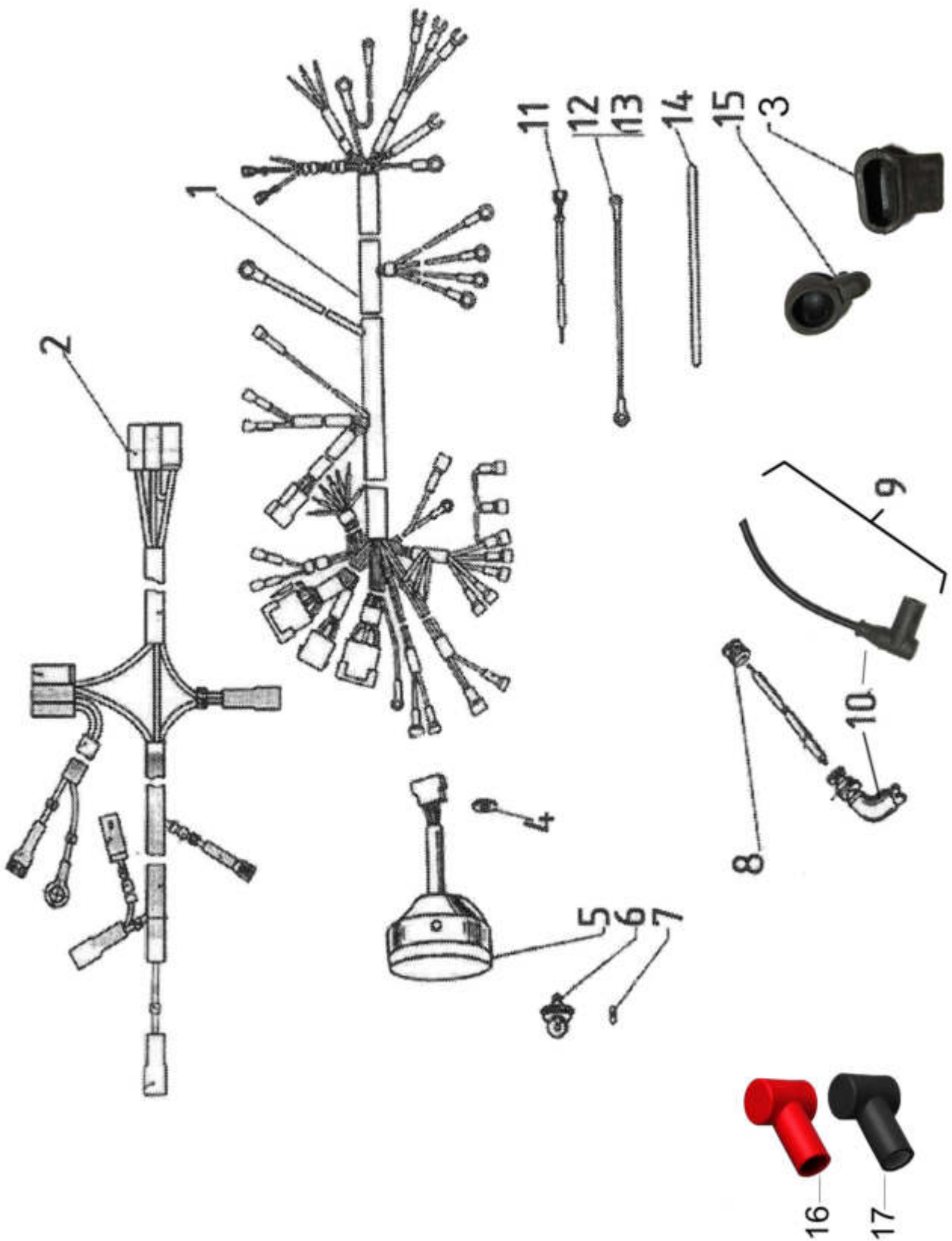
**from 2012**



**from 2013**



Fig. 44



**Fig. 46**

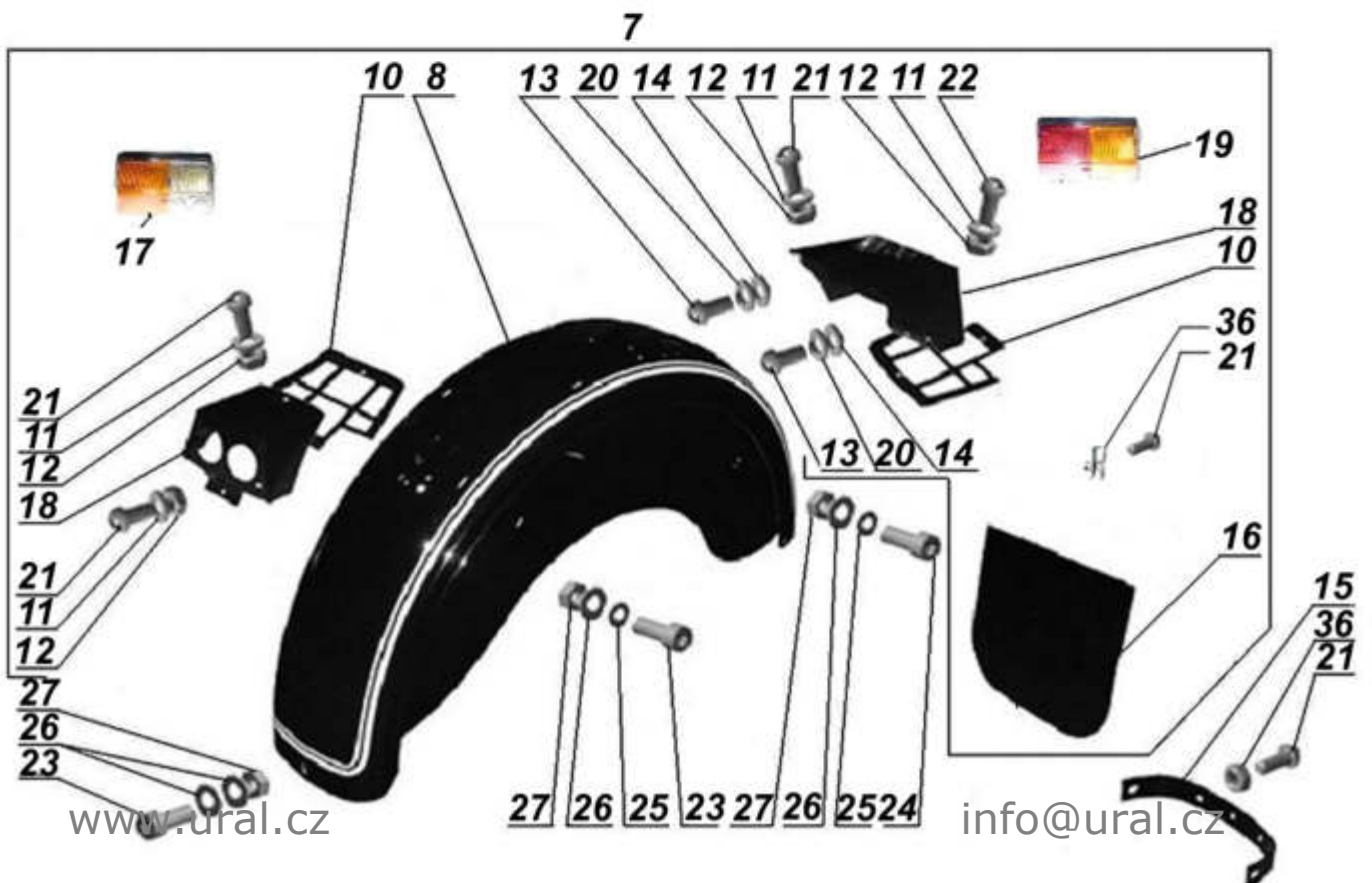
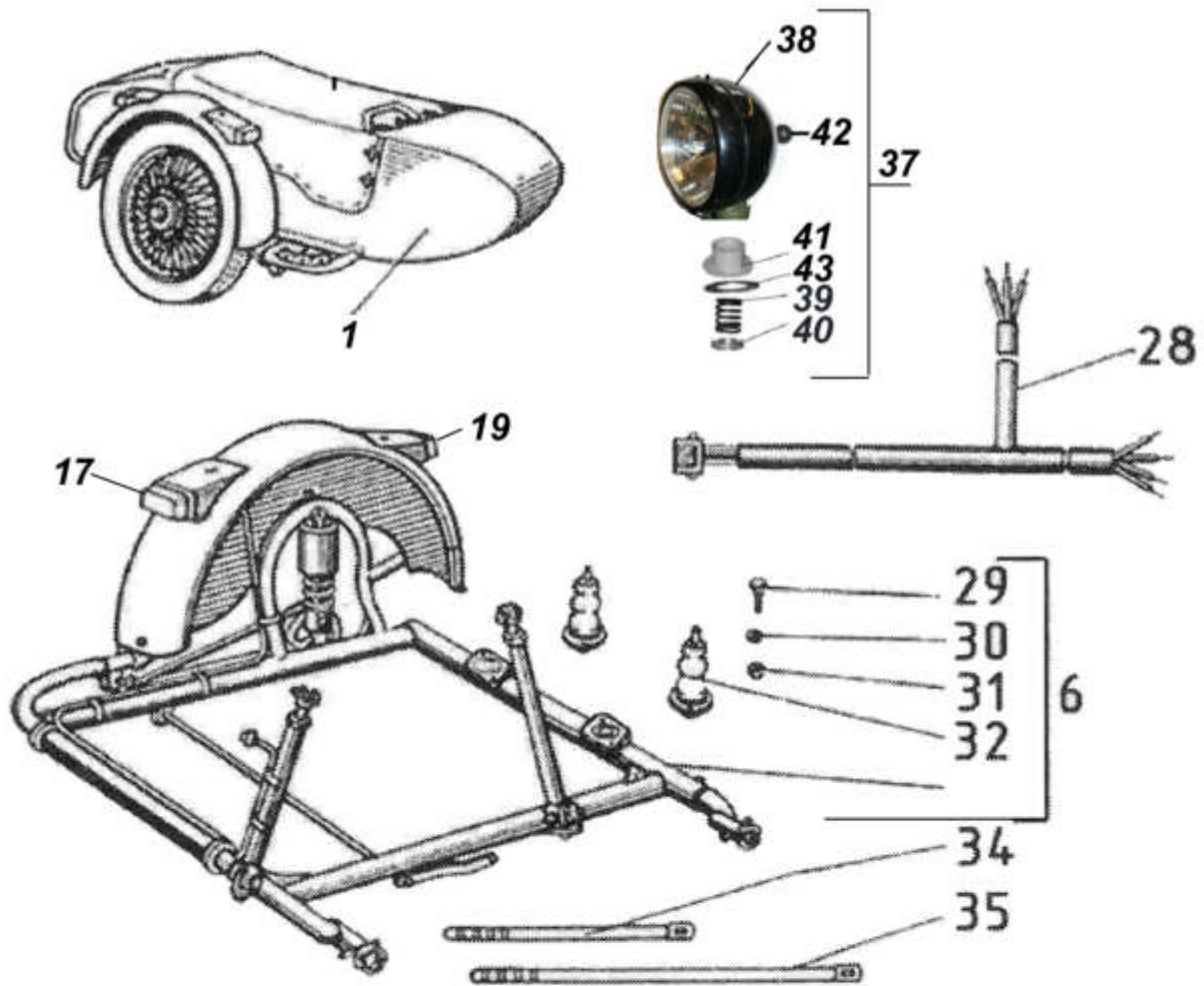






Fig. 47.02

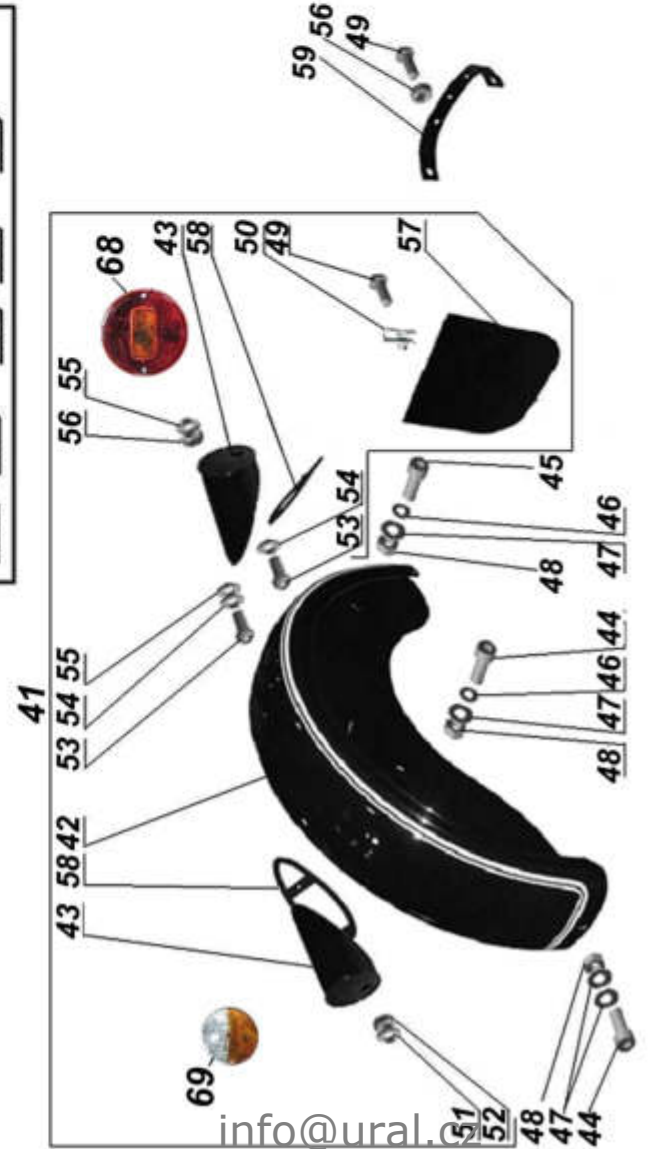
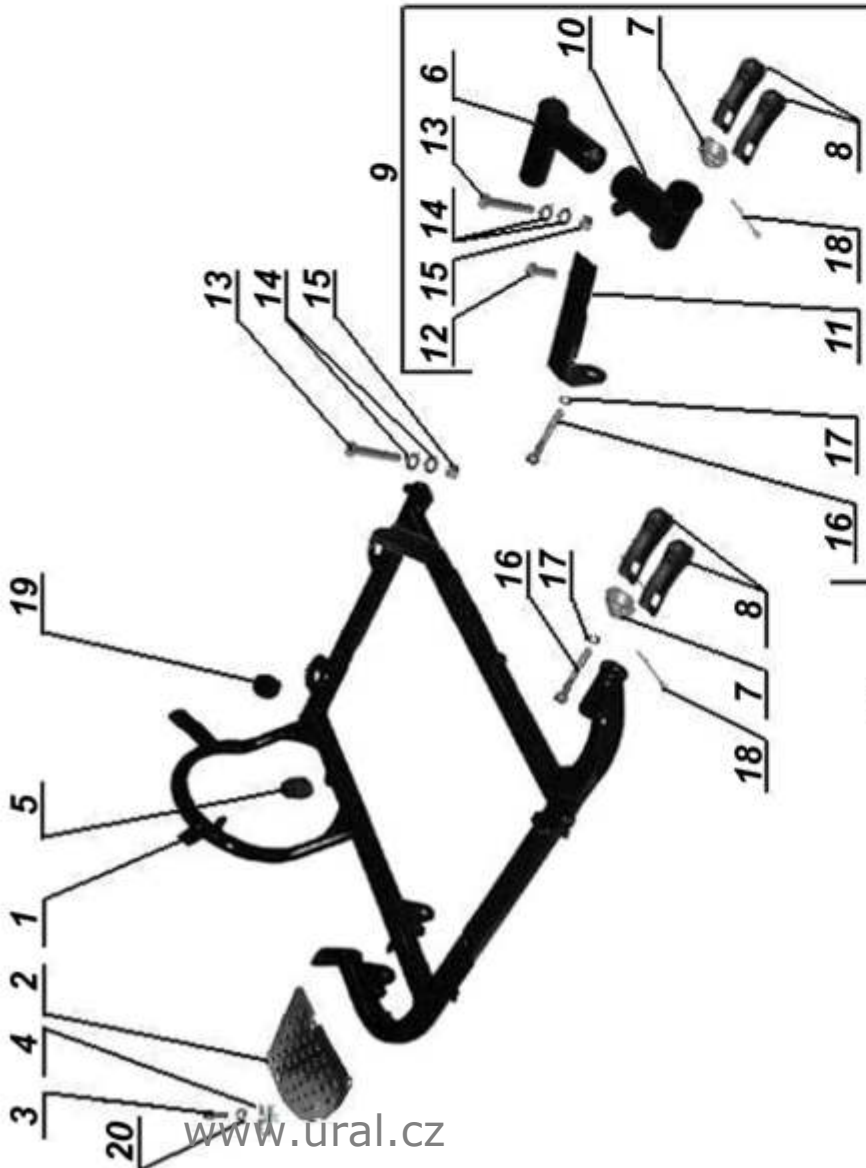
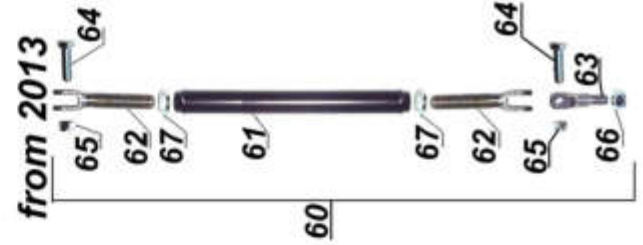
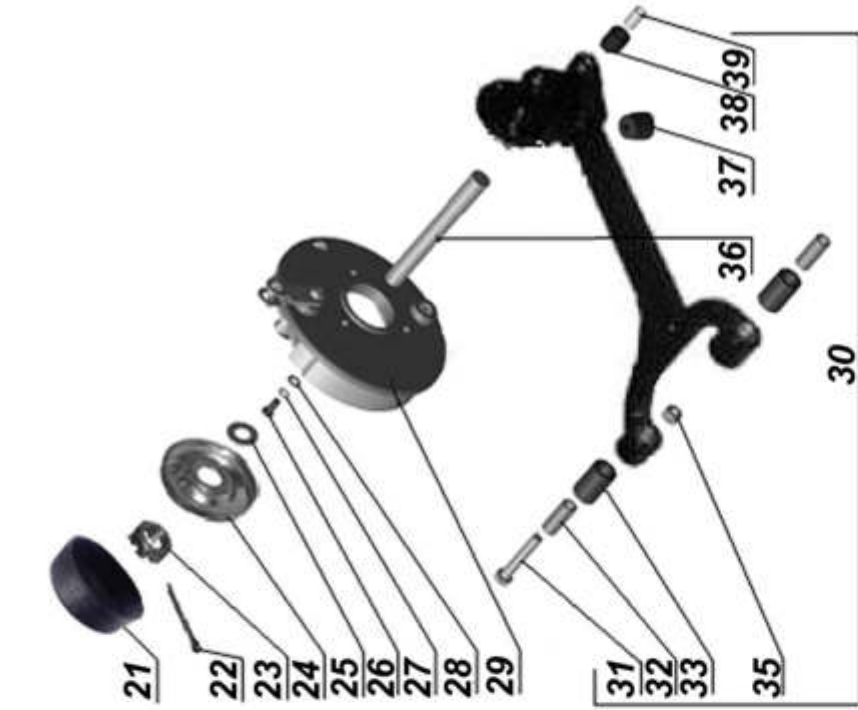


Fig. 48

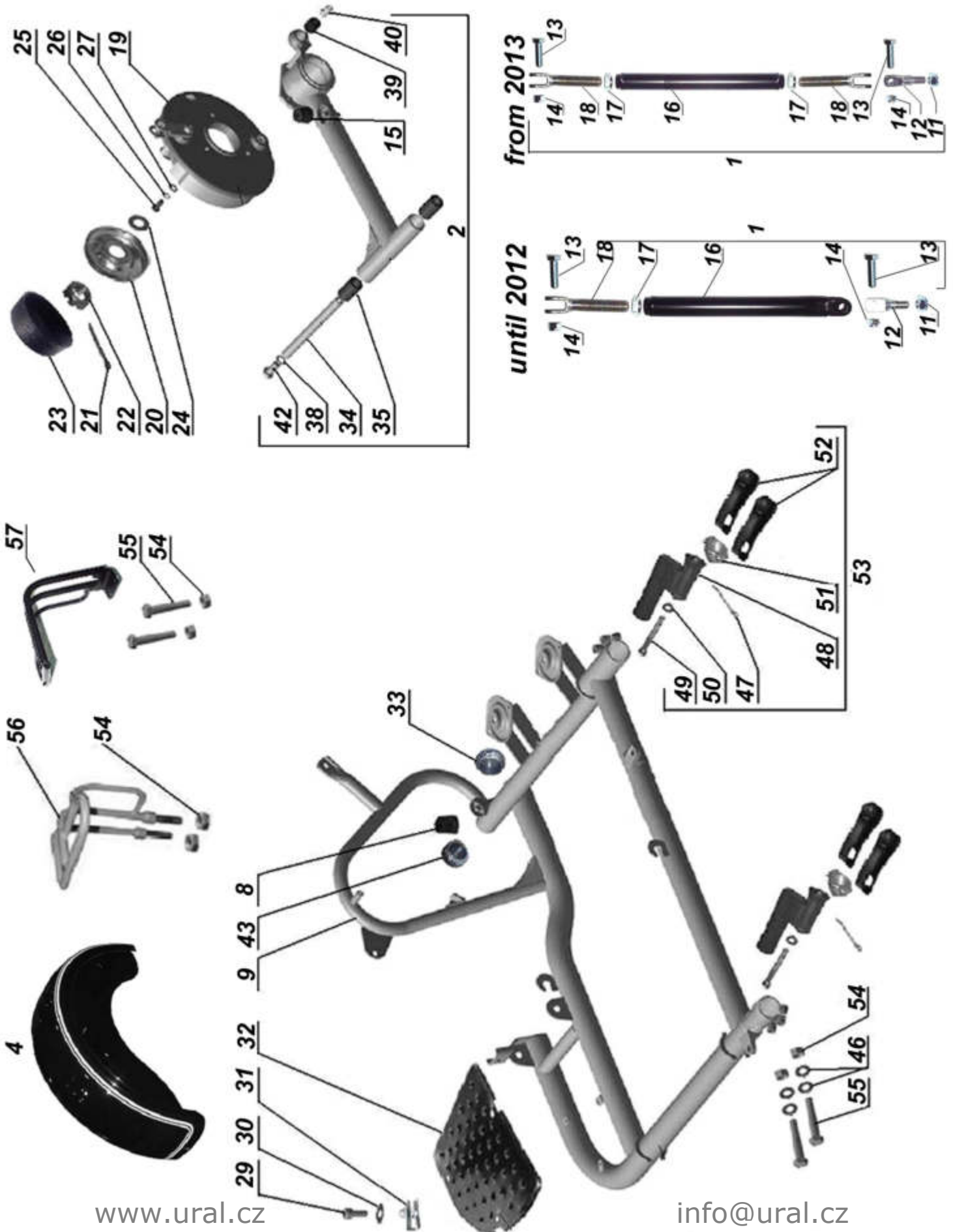


Fig. 49

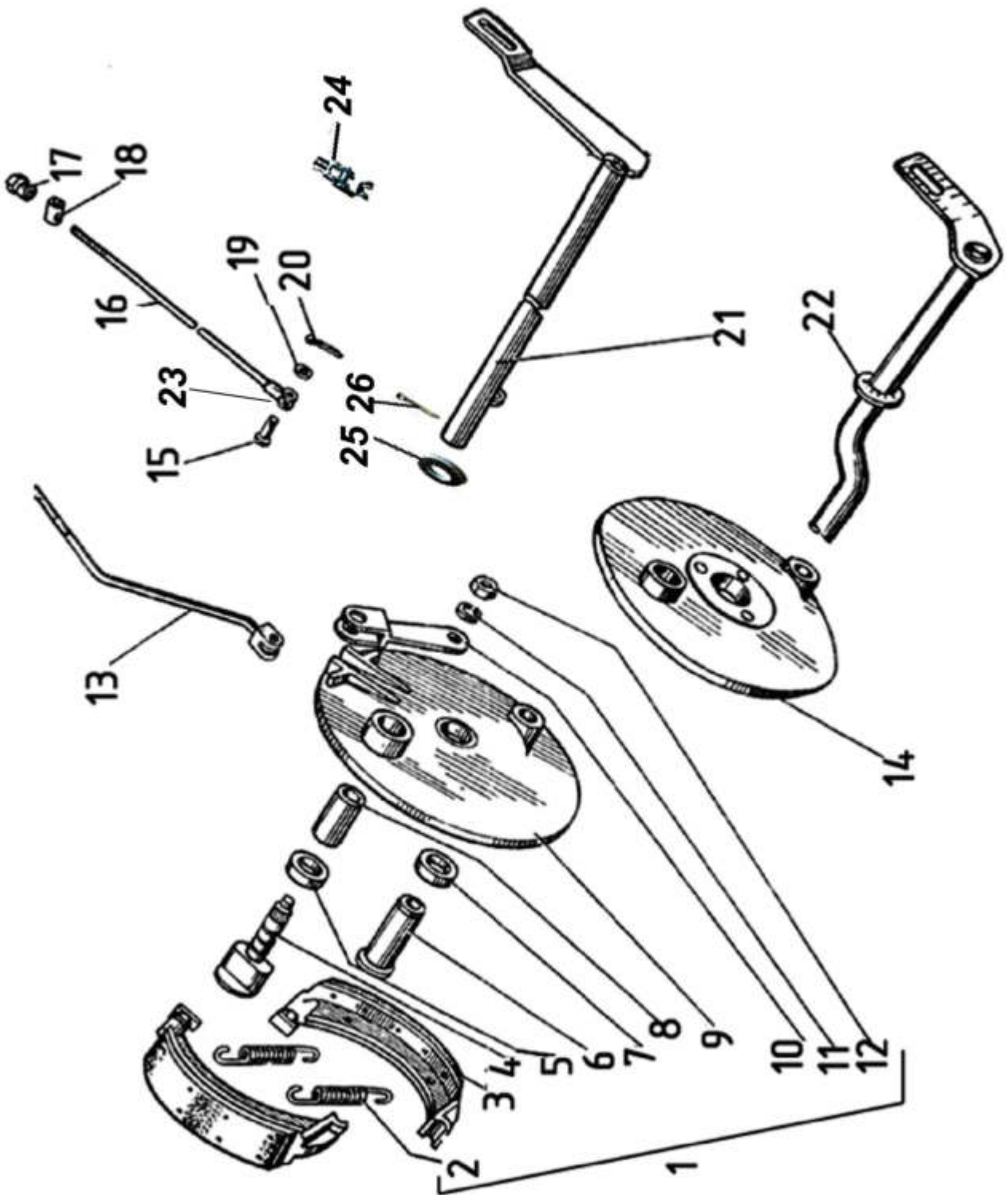


Fig. 50

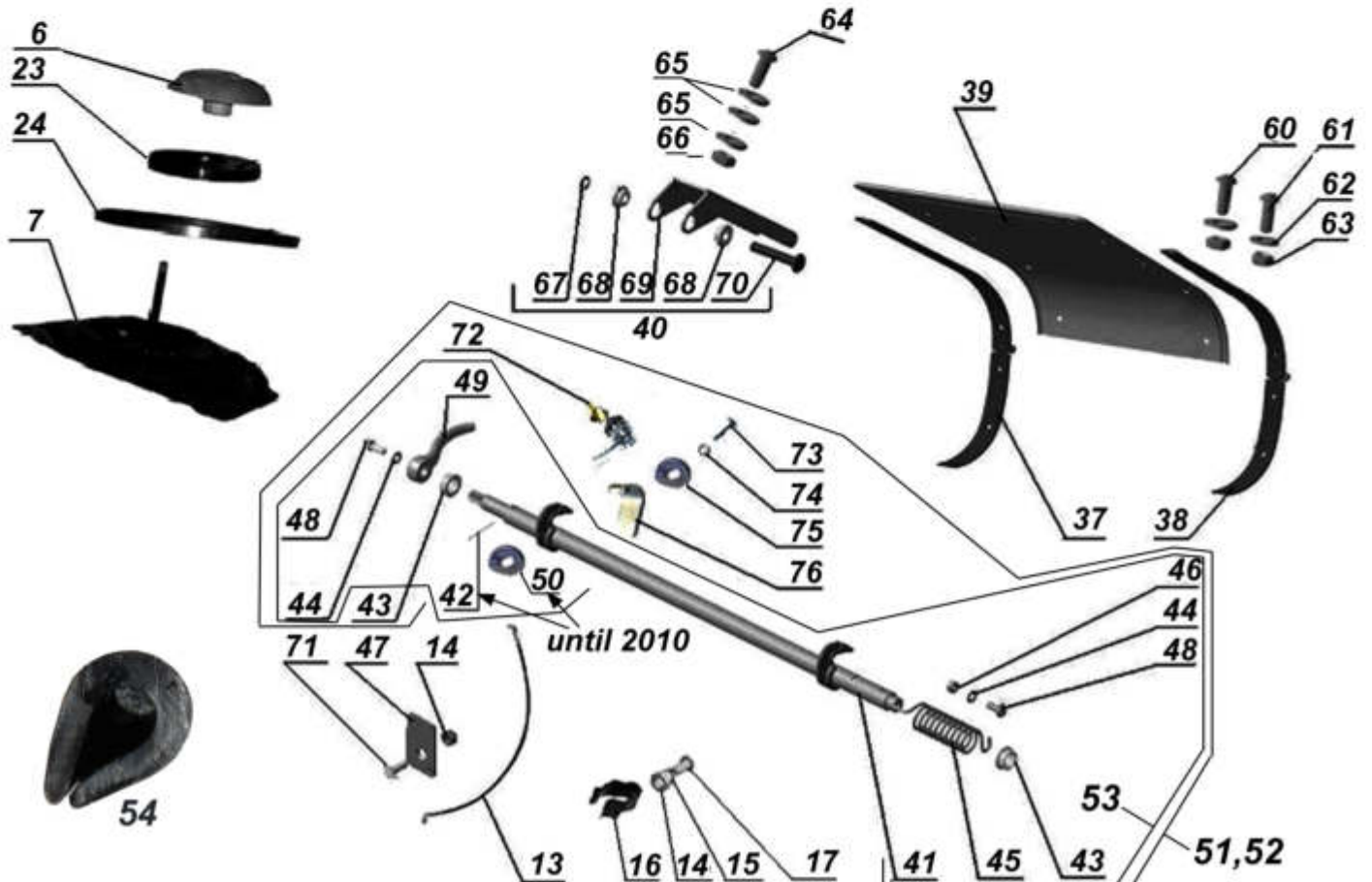
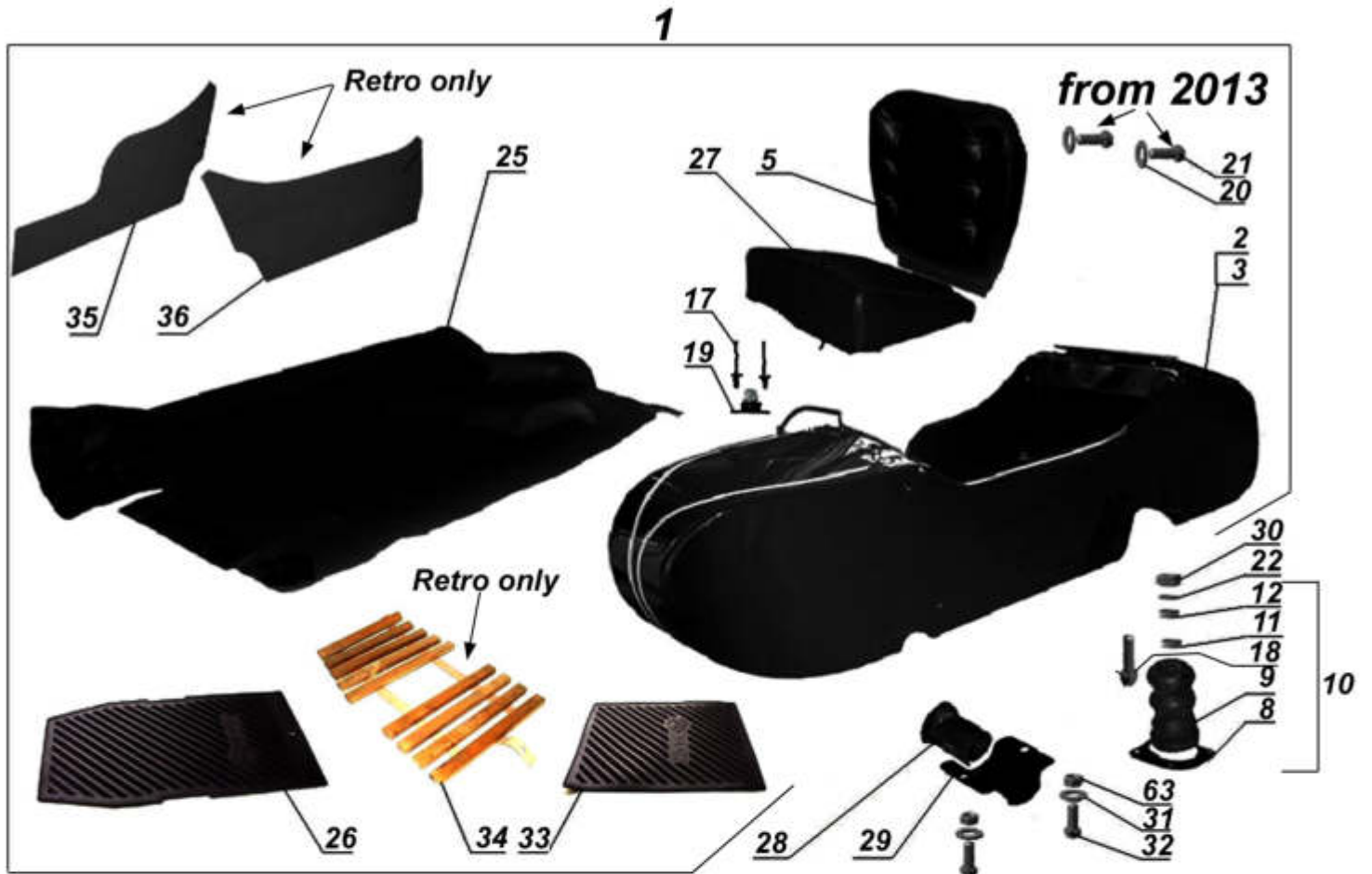
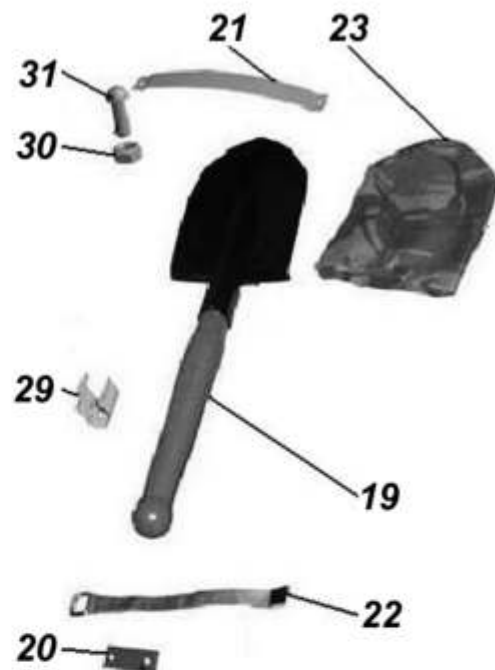
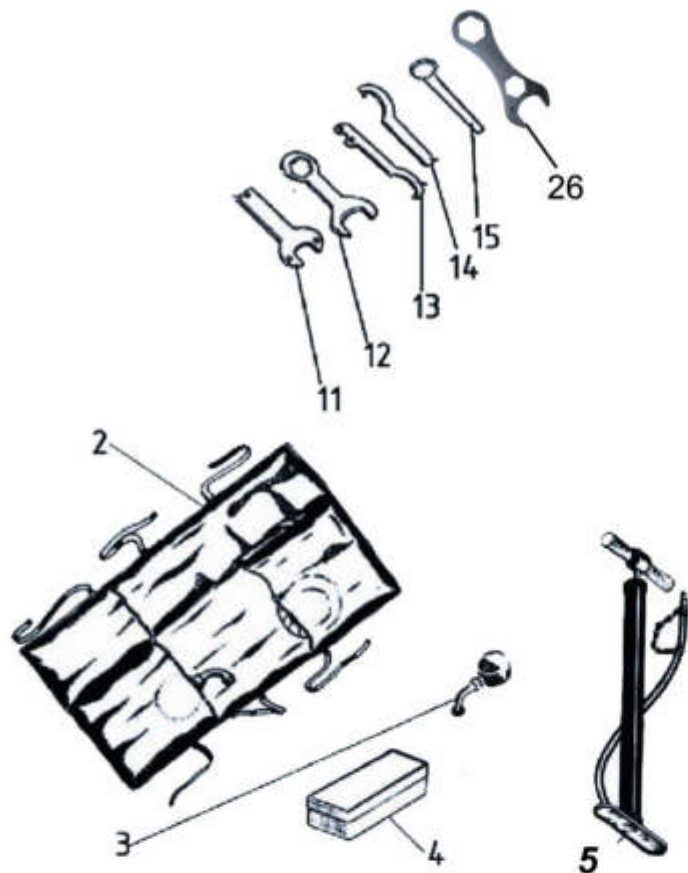


Fig. 51



1



2



25

